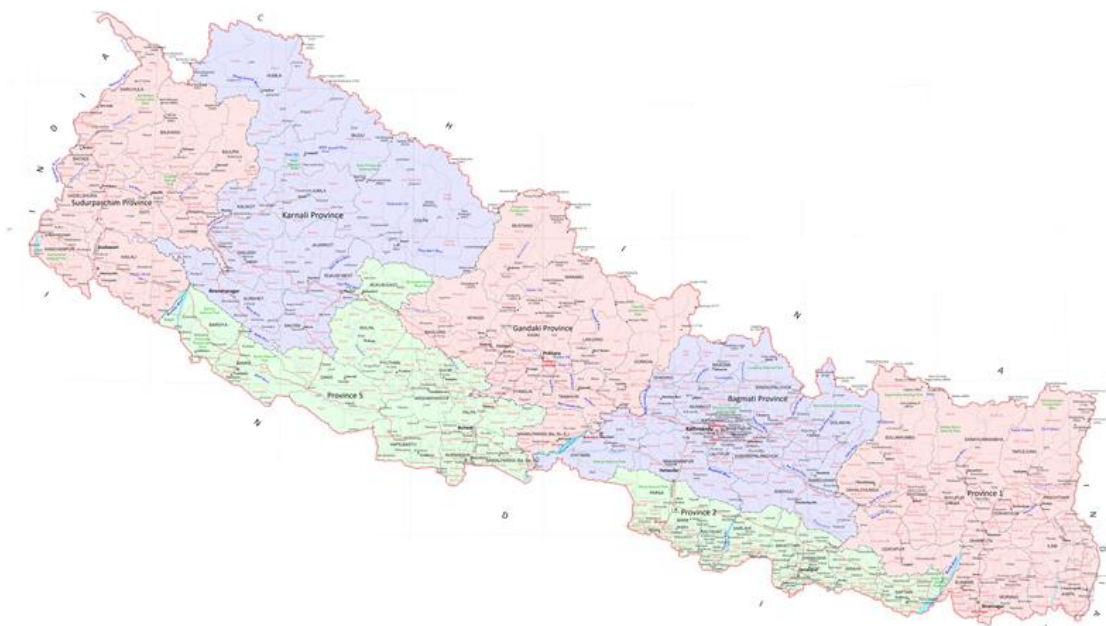




NEPAL NATIONAL BUILDING CODE

NBC 205: 2024



READY-TO-USE DETAILING GUIDELINE FOR LOW RISE REINFORCED CONCRETE BUILDINGS WITHOUT MASONRY INFILL

Compliance with it does not confer immunity from relevant legal requirements, including bylaws.

मिति २०८१।०१।३० को नेपाल सरकार (मन्त्रीस्तरीय) निर्णयानुसार स्वीकृत र मिति २०८१।०२।२८ को नेपाल राजपत्रमा सूचना प्रकाशित

Government of Nepal

Ministry of Urban Development

Department of Urban Development and Building Construction

Babar Mahal, Kathmandu, Nepal

2081

Preface

This code is the first & complete revision of the earlier version of NBC 205:1994 which supersedes its earlier version.

The main objective of the code has been kept the same which is to provide ready to use drawings for various structural & non-structural elements of reinforced concrete frame structured buildings falling under Building Category C according to the clause 8(c), Building Act, 2055. Further limitations are prescribed in the code which shall be duly complied.

The basic purpose of the code is to regulate building construction in municipalities and rural municipalities where professional engineers and technicians are not available and buildings are constructed under the guidance and supervision of for mid-level technicians (sub-engineers).

The earlier version of this code was based on the seismic design code NBC 105:1994 which has been revised as NBC 105:2020. Thus, due to the revision in the seismic code, this code is also revised accordingly.

Various possible configurations of buildings are structurally designed according to NBC105:2020 and the most critical configuration of building is used to prescribe the structural drawings for two storey and three storey buildings with different soil types and seismic zone factors separately. Accordingly, the respective structural drawings can be readily adopted for approval from the municipalities.

The code is revised with rigorous study, series of consultations and discussions with experts, professionals and stakeholders in Department of Urban Development and Building Construction (DUDBC). The suggestions and recommendations were incorporated and the proposed revised code was submitted to Building Construction Management Upgrading Consolidation Committee under the chairmanship of Secretary, Ministry of Urban Development (MoUD) for approval. The revision of NBC 205:2024 was finally recommended by committee to MoUD for approval in 2080/11/30 and according to clause 9 (2) of Building Act, 2055, it was approved by MoUD (minister level) in 2081/1/30.

NBC 205:2024 "Ready to Use Guideline for Low Rise Reinforced Concrete Buildings without Masonary Infill" is approved for mandatory application by terminating NBC 205:1994 "Mandatory Rules of Thumb Reinforced Concrete Buildings without Masonary Infill" and according to Clause 18(1), Building Act 2055, the notice was published in Nepal Gazette dated 2081/02/28 for public notification.

1. BuildingConstructionManagementUpgrading(Consolidation) Committee

Chairman

Mr.Maniram Gelal Secretary, Ministry of Urban Development

Members

Mr. Rajesh Babu Ghimire Representative, National Planning Commission

Mr. Dal Bahadur Adhikari Representative, Ministry of Law, Justice and Parliamentary Affairs

Mrs. Kumari Jyoti Joshi Representative, Nepal Bureau of Standards and Metrology

Prof. Dr. Sangeeta Singh Representative, Dean Office, Institute of Engineering, TU

Mr. Ram Nath Prasad Yadav	Executive Director, Research Center for Applied Science & Technology
Mr. Manohar Rajbhandari	Expert
<i>Member–Secretary</i>	
Mr. Kumar Prasad Ghimire	Director General, Department of Urban Development and Building Construction (DUDBC)

2. Inputs for this revision came from

Er. Dilip Bhandari	Joint Secretary, MOUD
Er. Narayan Prasad Bhandari	DDG, Urban Development, DUDBC
Er. Prakirna Tuladhar	DDG, Building Division, DUDBC
Er. Machakaji Maharjan	DDG, Housing Division, DUDBC
Prof. Dr. Gokarna Bahadur Mortha	Institute of Engineering, Pulchowk Campus
Prof. Dr. Prachanda Man Pradhan	Manmohal Technical University
Dr. Kshitij Charan Shrestha	Institute of Engineering, Pulchowk Campus
Dr. Rajan Suwal	President, SEANep
Dr. Purushotam Dangol	Expert
Er. Manoj Nakarmi	SDE, DUDBC
Er. Ganesh Karmacharya	SDE, DUDBC
Er. Debendra Dev Khanal	Structural Engineer, DUDBC
Er. Madhav Katuwal	Civil Engineer, DUDBC
Er. Ashish K.C	Structural Engineer, DUDBC
Er. Dwarika Shrestha	Expert
Er. Sagar Kr. Joshi	Expert
Er. Binaya Charan Shrestha	Expert
Er. Manoj Bista	Expert
Er. Rajan Khadka	Structural Engineer
Er. Suraj Malla	Structural Engineer
Er. Ugen Maharjan	Structural Engineer, DUDBC
Er. Ukesh Dawadi	Civil Engineer, DUDBC
Er. Manjil Joshi	Civil Engineer, DUDBC

Er. Suraj Kafle

Civil Engineer, DUDBC

Er. Pramod Kumar Shahi

Civil Engineer, DUDBC

Er. Praveen Regmi

Geotech Engineer, DUDBC

We would like to express our sincere thanks to all those who contributed directly and indirectly to the revision of this code. We hope the revised code will be useful to all as it incorporates the recent knowledge and technology in the sector.

v
TABLE OF CONTENTS

1.	BuildingConstructionManagementUpgrading(Consolidation) Committee....	ii
2.	Inputs for this revision came from.....	iii
1.	Scope.....	2
1.1	General.....	2
1.2	Related Standards.....	2
2.	Interpretation.....	3
2.1	General.....	3
2.2	Terminology.....	3
2.3	Symbols.....	5
3.	Selection and Investigation of Site.....	6
3.1	General.....	6
3.2	Use of Local Knowledge.....	6
3.3	Site Investigation Requirements.....	6
3.4	Allowable Bearing Pressure.....	7
3.5	Dropping Weight Method.....	7
4.	The Building Structure.....	9
4.1	Description.....	9
4.2	Restrictions on the Structural Layout.....	9
5.	Construction Materials.....	12
5.1	Concrete.....	12
5.2	Brickwork.....	12
5.3	Reinforcing Steel Bars.....	12

6.	Design Procedure Adopted	14
6.1	Procedure Outline	14
6.2	Seismic Base Shear Calculation from Equivalent Static Method	14
6.2.1	Elastic Site Spectra.....	15
6.2.1	Site Subsoil Category.....	16
6.2.2	Seismic Zoning Factor (Z).....	16
6.3	Vertical Distribution of Total Horizontal Seismic Base Shear	17
6.4	Preparation of Numerical Model of Building.....	17
7.	Design of the Frames	18
7.1	Preparation of Numerical Model of Building Frames.....	18
7.2	Design.....	18
7.2.1	Basis of Recommendations.....	18
7.3	Foundation Design	19
7.3.1	Basis of Recommendations.....	19
7.4	Recommended Members Sizes and Reinforcement.....	19
8.	Two Storey Building.....	21
8.1	Foundation.....	21
8.1.1	Isolated Footing.....	21
8.1.1	Eccentric Isolated Footing	26
8.2	Column.....	31
8.3	Beam.....	38
9.	Three Storey Building.....	52
9.1	Foundation.....	52
9.1.1	Isolated Footing.....	52
9.2.1	Eccentric Isolated Footing	57

9.2	Column.....	62
9.3	Beam.....	71
10.	Slab and Staircase	87
10.1	Slab.....	87
10.2	Staircase	98
11.	Reinforcing Non-Load Bearing Walls.....	102
11.1	Between Framing Columns	102
11.1.1	Solid Walls	102
11.2	Walls with Openings.....	103
12.	Parapets	106
12.1	General	106
12.2	Flower Pots.....	106

A Foreword

A.1 Introduction

For the last 30 to 35 years, there has been a proliferation of reinforced concrete (RC) framed buildings constructed in the urban and semi-urban areas of Nepal. Most of these buildings have been built on the advice of mid-level technicians and masons with minimum professional structural design input. These buildings have been found to be significantly vulnerable to a level of earthquake shaking that has a reasonable chance of happening in Nepal. Hence, these buildings, even though built with modern materials, could be a major cause of loss of life in future earthquakes. Moreover, with the publication of Nepal National Building Code NBC 105:2020 “Seismic Design of Buildings in Nepal”, the need for updating of this document was imminent. Upgrading the structural quality of future buildings of this type is essential in order to minimise the possible loss of life due to their structural failure.

A.2 Objective

The main objective of this Ready-to-Use Detailing Guideline (RUD) is to provide ready-to-use dimension and detail for various structural and non-structural elements for up to three-storey reinforced concrete (RC) framed, ordinary residential buildings commonly being built by owner-builders in Nepal.

This RUD is intended to cater primarily to the requirements of mid-level technical personnel who are not trained to undertake independently the structural design of buildings.

A.3 Limitations

The requirements set forth in this guideline shall be applicable only for buildings complying with the specified limitations as mentioned under clauses 4.1 and 4.2 of this guideline. The intention is to achieve a minimum acceptable structural safety, even though it is always preferable to undertake site specific investigation and design.

Owners and builders must use the services of competent professional engineers/designers for design of buildings not covered by this RUD.

1. Scope

1.1 General

1.1.1 This RUD guideline addresses the particular requirements of those RC-framed buildings, which have become very common with owner-builders, who even undertake the construction of this type of buildings without employing professional designers. However, the users of this RUD are required to comply with certain restrictions with respect to building configuration, layout and overall height and size.

1.1.2 The RUD guideline is intended to use for building categorized under Category C under the Building Act, 2055 (1998) of Nepal.

1.1.3 The RUD guideline is intended for buildings of the regular column-beam type with reinforced concrete slabs for floors and the roof. The walls are assumed to be of burnt bricks, or hollow concrete or other rectangular blocks whose density will not exceed that of burnt bricks. Here, all the details are based on solid clay burnt bricks. These can be replaced by the above described blocks. The buildings shall comply with limitations listed in **Cl 4.1, 4.2. in order to be designed by using this RUD guideline.**

1.1.4 The RUD guideline presents ready-to-use designs for all structural components, including detailing of structural as well as non-structural members for the ordinary residential type of building.

1.1.5 Proportioning of structural components represented in this RUD guideline is for ordinary residential buildings located in seismic zone and site subsoil categories (C & D) as classified by NBC 105: 2020.

1.1.6 The building could, of course, be alternatively designed using the prevailing design standards for engineered structures. However, such design should also comply with NBC 105:2020. The design procedures here are simplified in order to save design time and to help owner-builder to adopt the recommended design and detail so that they will achieve earthquake-resistant structure.

1.2 Related Standards

The requirements of this RUD guideline are based on the following standards and documents. Compliance with this RUD guideline will, therefore, result in compliance with these Standards:

NBC 105: 2020 (Seismic Design of Buildings in Nepal)

IS 875 (Part I): 1987 (Dead Loads)/IS 875 (Part II): 1987 (Imposed Loads)

IS 456: 2000 (Plain and Reinforced Cement Concrete- Code of Practice)

SP 34 - 1987 (Handbook on Concrete Reinforcement Design & Detailing)

2. Interpretation

2.1 General

2.1.1 In this RUD guideline, the word 'shall' indicates a requirement that is to be adopted in order to comply with the provision of this document, while the word 'should' indicates recommended practice.

2.1.2 References to 'Code' indicate NBC 105:2020 Seismic Design of Buildings in Nepal.

2.1.3 Words implying to singular only also include the plural and vice versa where the context requires.

2.2 Terminology

In this Standard, unless inconsistent with the context, the following definitions shall apply:

Base Shear means total design lateral force or shear force due to earthquake at the base of structure.

Beam means the members (generally horizontal) of moment resisting frames which are subjected to flexural and shear actions.

Chair means an element made of steel bar which is used to maintain the vertical distance between top and bottom bars in slabs.

Column means the members (generally vertical) of moment resisting frames which are subjected to combination of axial, flexural and shear action.

Corner Column means the column at four corner however not categorized as staircase column.

Dead Load means the weight of all permanent components of a building including walls, partitions, columns, beams, floors, roofs, finishes and fixed plant and fittings that are integral parts of the structure.

Design means use of rational computational methods in accordance with the established principles of structural mechanics.

Development Length means the length of embedment necessary transfer the stress successfully into the concrete.

Extra Bar means the longitudinal bars that shall be provided in addition to regular bars as top bars and bottom bars in a beam and slab.

Face Column means all the column at peripheral side however not categorized as corner and staircase column.

Frame means a system composed of interconnected members functioning as a complete self-contained unit with or without the aid of horizontal diaphragms or floor-bracing systems.

Height of Storey means the distance between either top-to-top or bottom-to-bottom portion of two adjacent floor slabs.

Importance Factor means a factor used to adjust the design seismic forces depending on the functional use of the building.

Inter-Storey Drift means the relative displacement of adjacent floors.

Interior Column means the column at internal location of the building however not categorized as staircase column.

Irregular Building means the building, which contains any of the vertical, or plan irregularity mentioned in NBC 105:2020

Liquefaction means state in saturated cohesion less soil wherein the effective shear strength is reduced to negligible value due to pore water pressure generated by earthquake vibrations, when the pore water pressure approaches the total confining pressure. In this condition, the soil tends to behave like a liquid.

Live Load means the load assumed or known to result from the occupancy or use of a building and includes the loads on floors, loads on roofs other than wind, loads on balustrades, and loads from movable goods, machinery, and plants that are not integral parts of the building.

Longitudinal Bar means the horizontal/vertical steel reinforcement that runs through the length of the member, which is provided to resist flexure or tension in a member.

Lumped Mass means the theoretical concentration of the mass of adjacent upper and lower half storeys at any floor level.

Masonry Infill Wall means any wall constructed in brick with cement sand mortar inside the frame and not intended to carry horizontal load by equivalent compression strut action.

Moment Resisting Frame System means the assembly of beams and columns that resist internally produced and externally applied forces primarily by flexure and are specially detailed for ductility.

Non-Load Bearing Wall means any wall which is not intended to carry any significant external loads and which functions just as a cladding, partition wall or filler wall.

Ordinary Building means any building in accordance to NBC 105:2020 which falls under Importance Class I (E.g. residential, general commercial, ordinary offices, etc.).

Storey means the space between two adjacent floors.

Reinforcement/Rebar/Bar means the high-strength deformed bars Fe500 conforming to NS: 191-2046 with minimum yield strength $f_y = 500 \text{ N/mm}^2$.

Soft Storey means story in which the lateral stiffness is less than 70 per cent of the stiffness of the story above or less than 80 percent of the average lateral stiffness of the three stories above.

Soil Bearing Capacity means the allowable pressure that the underlying soil can safely transfer coming from the building to its foundation.

Step-back Building means the step-like recessions in the profile of a building from the building fronting.

Staircase Column means the column which encloses the staircase from four sides.

Staircase Cover means the area covering the staircase at the top whose area is less than the 25% of the building plan area for the use of this guideline.

Ties/Cross Ties means a continuous reinforcing rebar having a 135° hook with an extension of 6 times diameter (but not $< 65 \text{ mm}$) at each ends.

Through Bars means the rebars that is continuous and parallel to face of a beam.

Transverse Reinforcement means a continuous rebar profile bent in square, rectangular, triangular or trapezoidal shape, which may also include straight cross ties.

2.3 Symbols

A	Maximum Horizontal Length of Building
A_s	Area of Steel Bar
B	Maximum Horizontal Width of Building
$C(T)$	Elastic Site Spectra for Ultimate Limit State
$C_s(T)$	Elastic Site for Serviceability Limit State
$C_d(T_1)$	Design Seismic Coefficient
$Ch(T)$	Spectral Shape Factor
f_{ck}	Characteristic Compressive Strength of Concrete
F_i	Lateral Seismic Force Applied at Level i
f_y	Characteristic Strength of Rebar
H	Height of Building above the Lateral Restraint Imposed by Ground
I	Importance Factor
k	an exponent related to the structural period
K_1, K_2	Plan Length of Structural Wings
L_d	<i>Development Length</i>
RC	Reinforced Cement Concrete
SBC	Soil bearing capacity
T_1	Fundamental Time Period of Building
t_m	Maximum Thickness of the Pad Foundation
V	Design Base Shear
W	Seismic Weight of the Structure
W_i	Seismic Weight at Level i
Z	Seismic Zoning Factor
ϕ	Diameter of Steel Rebar
RUD	Ready to Use Detaling

3. Selection and Investigation of Site

3.1 General

This section sets out some of the requirements to be considered during site selection for the construction of buildings in order to minimise the risks to the buildings from primary geological as well as secondary seismic hazards such as fault rupture, landslides and liquefaction. A building shall not be designed using this RUD if the proposed site is:

- Water-logged
- A rock-falling area
- A landslide-prone area
- A subsidence and/or fill area
- A river bed or swamp area
- A steep sloping terrain which demands a step-back building

3.2 Use of Local Knowledge

It is a good practice during the construction of a building to examine the existing local knowledge and the history of the performance of existing buildings. This will assist in identifying whether there is any danger from inherent natural susceptibilities of the land to the processes of sliding, erosion, land subsidence and liquefaction during the past earthquakes or any other natural/geological processes likely to threaten the integrity of the building. The local practice of managing such hazards, if any, should be judged against the required level of acceptable risk.

3.3 Site Investigation Requirements

Site exploration shall be carried out by digging test pits, two as a minimum, and more if the subsurface soil condition shows a significant variation in soil type.

Generally, the minimum depth of exploration for a building covered by this RUD shall be 1.5 m. In hilly areas, exploration up to the depth of sound bed-rock, if it lies shallower than 1.5m, should suffice.

No exploration shall be required if the site is located on rock or on fluvial terraces (Tar) with boulder beds.

For classification of soil, it is always encouraged to refer to soil investigation report of neighbouring sites. However, for approximate judgement, the soil encountered in the test pits in conjunction with the visual classification should be classified as given in **Table 3-1**.

TABLE 3-1 VISUAL SOIL CLASSIFICATION

S. No.	Type of Foundation Materials	Soil Classification
1.	Rocks in different state of weathering, boulder bed, gravel, sandy gravel and sand-gravel mixture, dense or loose coarse to medium sand offering high resistance to penetration when excavated by tools, stiff to medium clay which is readily indented with a thumb nail.	Hard
2.	Fine sand and silt (dry lumps easily pulverized by the finger), moist clay and sand-clay mixture which can be indented with strong thumb pressure	Medium
3.	Fine sand, loose and dry; soft clay indented with moderate thumb pressure	Soft
4.	Very soft clay which can be penetrated several centimeters with the thumb	Weak

3.4 Allowable Bearing Pressure

The allowable bearing pressure can be approximated by using “Dropping Weight Method” as explained in **Cl 3.5** and the approximate value of soil bearing capacity is given in **Table 3-2**

3.5 Dropping Weight Method

The procedure to find out the soil bearing capacity by this method is as follows:

1. Excavate a pit of required depth equal to the depth of foundation (1.5m).
2. Stack four full size standard bricks on top of each other with the help of strings.

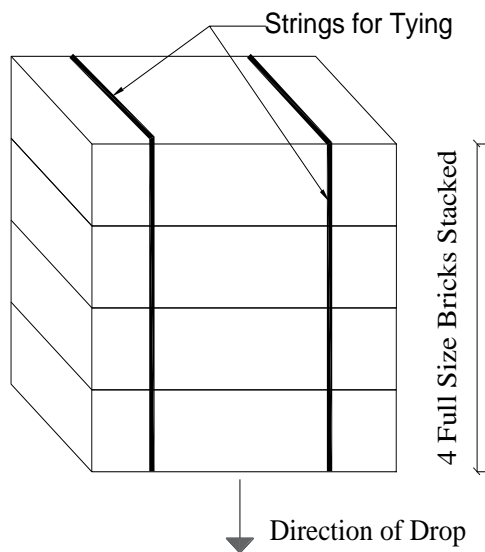


FIGURE 3-1 DROPPING WEIGHT METHOD FOR APPROXIMATION OF SBC

3. Drop the bricks on the test pit from a known height of 1.5m.

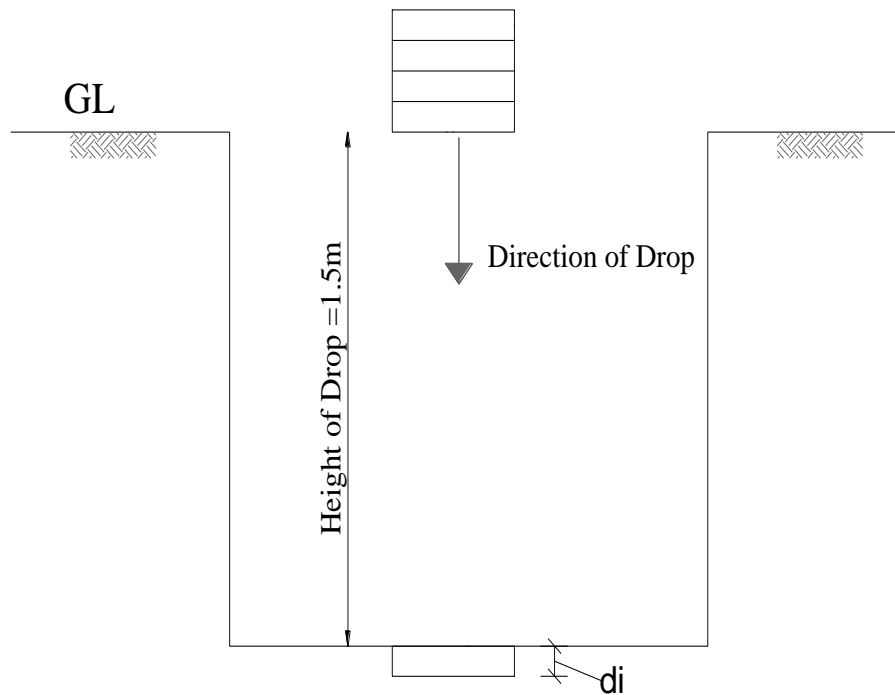


FIGURE 3-2 DROPPING WEIGHT METHOD FOR APPROXIMATION OF SBC

4. Measure the impression (d_i) made on the pit by bricks using a ruler. Drop at three different location of the same pit and calculate the average depth of impression

$$(d_{avg} = \frac{d_1+d_2+d_3}{3})$$

TABLE 3-2 APPROXIMATION OF SOIL BEARING CAPACITY OF FOUNDATION SOIL

S. No.	Impression d_{avg} (mm)	Soil bearing capacity (kN/m ²)
1.	$\leq 12\text{mm}$	200
2.	$> 12\text{mm} \ \& \ \leq 17\text{mm}$	150
3.	$> 17 \text{ mm} \ \& \ \leq 20\text{mm}$	125
4.	$> 20 \text{ mm}$	100

[Note:

- 1) The pit should be excavated such that the bottom of the pit is free from loose soil and undulation without application of excessive external compaction.
- 2) The bricks should be stacked on top of each other by its flat surface and tied by a string such that when dropped they don't fall apart.
- 3) The stacked bricks should be allowed to drop freely under its own weight vertically on the test pit.
- 4) In no condition, the excavation depth for test pit should be less than 1m. However, for such undesirable case where excavation depth is less than 1.5m, the drop height should be maintained at 1.5m from the bottom surface of the test pit.]

4. The Building Structure

4.1 Description

The structure is a reinforced concrete frame without any contribution of masonry infill walls in resisting the vertical or seismic loads. The frame shall comply with **CI 4.2** and be designed to resist earthquake forces as a bare frame.

4.2 Restrictions on the Structural Layout

For a structure to be built using this RUD guideline, it shall comply with the restrictions set out below. If the structure does not comply, it must be designed in accordance with the standards referred in **CI 1.2** or any latest appropriate standard accepted by Government of Nepal.

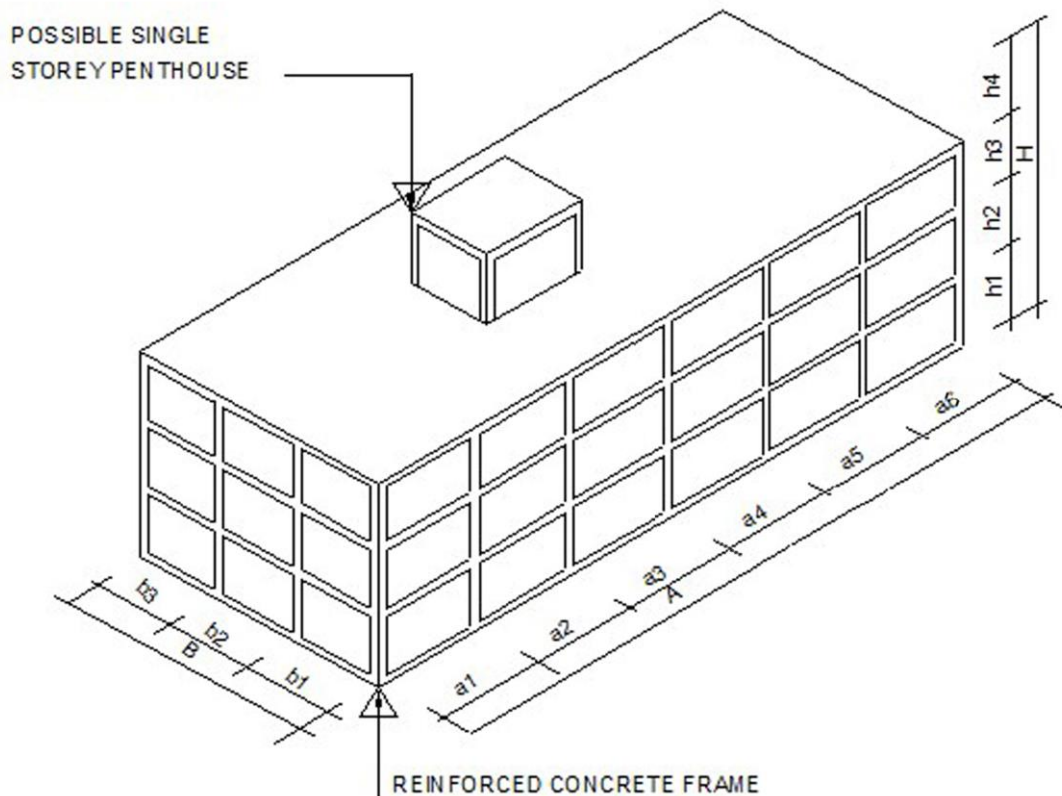


FIGURE 4-1 SCHEMATIC DIAGRAM OF REINFORCED CONCRETE FRAME

CONDITIONS FOR DETAILED DIMENSIONS

A	\leq	$3 \times B$
$a \times b$	\leq	13.5 sq. m
a, b	\leq	4.5m
a, b	\geq	2.1m
$A \text{ or } B$	\leq	6 bays
$A \text{ or } B$	\geq	2 bays
H	\leq	$12\text{m or } 3 \text{ Stories (whichever is less)}$
h_4	$=$	2.4m
$h_1 \geq h_2 \geq h_3 \geq h_4$		

[Note:

- i. Openings can be provided as per functional/architectural requirements.
- ii. Foundation is not shown]

The restrictions are:

- a) Neither A nor B shall exceed 6 bays in length nor 25 metres. Each bay shall not exceed 4.5 m, maximum panel area $a_i \times b_i \leq 13.5$ sq. m, as shown in **Figure 4-1**.
- b) A shall not be greater than $3B$ nor less than $B/3$.
- c) Neither H/A nor H/B shall exceed 3.
- d) The maximum height of the structure is 12 m or 3 storeys, whichever is less, from the level of lateral restraint. Within a 12 m height, there may be an additional storey of smaller plan area. The area of this shall not exceed 25 % of the area of a typical floor, as given in **Figure 4-1** and storey height limited to 2.4m. If the limit is exceeded, it shall be considered as an additional storey.
- e) The maximum height of single storey shall be restricted to 3.2m. Also, the height of upper storey shall be maintained equal or less than the height of storey below as given in **Figure 4-1**.
- f) The length of wings on the structure shall be restricted such that K_1 and K_2 shall be less than the lesser of $0.15A$ or $0.15B$. The width of the wings shall be restricted as shown in **Figure 4-2**. The plan shape of the building excluding wings shall be rectangular.
- g) Coverage area shall not exceed 1000 Sqft in any case.

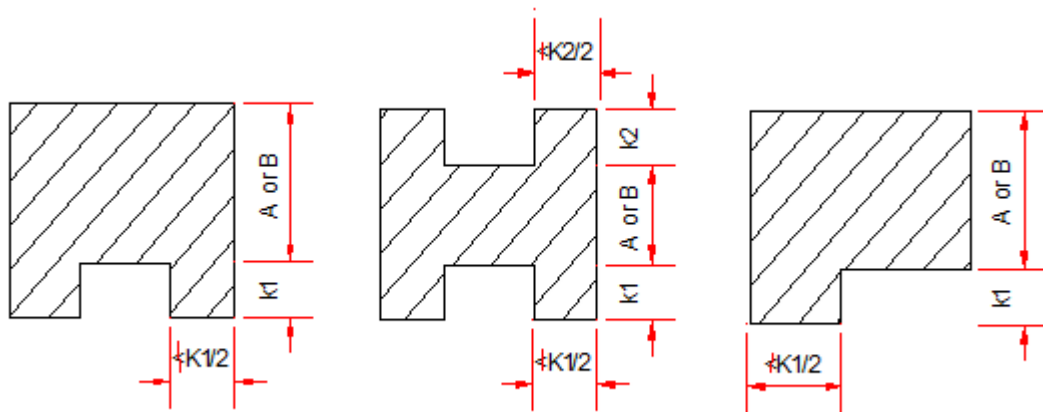


FIGURE 4-2 RESTRICTION ON PLAN PROJECTION

$K_1, K_2 < 0.15A$ or $0.15B$, whichever is less.

- h) All columns resisting lateral load shall be vertical and shall continue on the same centreline down to foundation level. The top storey may, however, be smaller or

have a different geometry subject to the provisions of subparagraph (e) above.

- i) No walls except a parapet wall shall be built on a cantilevered slab. Such walls shall be constructed only if the cantilevered slab is framed with beams.
- j) The foundation shall be at a uniform level.
- k) Buildings shall not have any irregularity.
- l) The size of cantilever projection should not exceed 1 metre.
- m) The occupancy type of building shall be normal residential only.

5. Construction Materials

5.1 Concrete

The concrete to be used in footings, columns, beams and slabs, etc., shall have a minimum compressive strength of 20 N/mm² (1:1.5:3) at 28 days for a 150 mm cube.

Cement: Cement shall be as fresh as possible. Any cement stored for more than two months from the date of receipt from the factory should either be avoided or tested and used only if the test results are found to be satisfactory. Any cement which has deteriorated or hardened shall not be used. All cement used shall be Ordinary Portland Cement meeting the requirements of NS 572:2076. It is advisable to use cement which has obtained the NS mark if independent tests are not carried out.

Coarse Aggregates: Coarse aggregates shall consist of crushed or broken stone and shall be hard, strong, dense, durable, clean, of proper grading and free from any coating likely to prevent the adhesion of mortar. The aggregate shall be generally angular in shape. As far as possible, flaky, elongated pieces shall be avoided. The aggregate shall conform to the requirements of IS 383:2016.

The coarse aggregates shall be of following sizes:

- (a) Normal cement concrete with a thickness of 100 mm and above - graded from 20 mm downwards
- (b) Cement concrete from 40 mm to 100 mm thick - graded from 12 mm downwards

Sand: Sand shall consist of a siliceous material having hard strong, durable, uncoated particles. It shall be free from undesirable amounts of dust lumps, soft or flaky particles, shale, salts, organic matter, loam, mica or other deleterious substances. In no case shall the total of all the undesirable substances exceed five percent by weight.

5.2 Brickwork

The brick masonry shall be built with the usually specified care regarding pre-soaking of bricks in water, level bedding of planes fully covered with mortar, vertical joints broken from course to course and their filling with mortar fully.

Bricks: The bricks shall be of a standard rectangular shape, well burnt, hand-formed or machine-made, and of crushing strength not less than 3.5 N/mm². The standard brick size of 230 x 115 x 57 mm with 10 mm thick horizontal and vertical mortar joints is preferable. Tolerances of -10 mm on length, -5 mm on width and ± 3 mm on thickness shall be acceptable for the purpose of thick walls in this RUD.

Wall Thickness: A minimum thickness of one half-brick and a maximum thickness of one brick shall be used.

Mortar: Cement-sand mixes of 1:6 and 1:4 shall be adopted for one-brick and half-brick thick walls, respectively. The addition to the mortars of small quantities of freshly hydrated lime in a ratio of $\frac{1}{4}$ to $\frac{1}{2}$ of the cement will greatly increase their plasticity without reducing their strength. Hence, the addition of lime within these limits is encouraged.

Plaster: All plasters should have a cement-sand mix not leaner than 1:6. They shall have a minimum 28 days' cube crushing strength of 3 N/mm².

5.3 Reinforcing Steel Bars

Reinforcing steel shall be clean and free of loose mill-scale, dust, loose rust and coats of paints, oil, grease or other coatings, which may impair or reduce bond. It shall conform to

the following NS.

High-strength deformed bars Fe500 conforming to NS 191:2046 with minimum yield strength $f_y = 500 \text{ N/mm}^2$ (preferably Fe 500D) and produced by the thermo-mechanical treatment process and having elongation more than 15 percent shall be used for longitudinal and transverse reinforcements for all concrete structural members. However, depending on the availability of steel reinforcement of grade Fe 415 may be used for reinforcement for sill/lintel bands.

6. Design Procedure Adopted

6.1 Procedure Outline

The simplified design procedure comprises the following stages:

A Super-structure

- a) Confirm that the building plan meets the structural layout restrictions (**CI 4.2**).
- b) Preparations of 3D numerical model of the building considering effective stiffness of different structural components.
- c) Determination of seismic zone and site subsoil category as per **CI 6.2.1**.
- d) Calculation of total horizontal seismic base shear coefficient for Ultimate Limit State (ULS) and Serviceability Limit State (SLS) using specified time period and spectral shape factor for equivalent static method.
- e) Distribution of total horizontal seismic base shear up to the height of the building (**CI 6.3**).
- f) Check for Inter-Story Drift & Deflection. The ratio of the inter-story deflection to the corresponding story height shall not exceed:
 - i. **0.025** at ultimate limit state
 - ii. **0.006** at serviceability limit state
- g) Defining load combinations as per NBC 105:2020 and design of columns & beams conforming both NBC 105:2020 and IS456:2000.
- h) Check for strong column weak beam actions as per NBC 105:2020.
- i) Check for design and detailing criteria of structural members as per NBC 105:2020.
- j) Detailing of the column and beam members.
- k) Recommendation of minimum sizes of column and beam from pre-determined seismic zone and site subsoil category for either two storey or three storey structure. (**Section 8 & 9**).
- l) Selection of respective sizes, longitudinal reinforcement, transverse reinforcement of frame from **Section 8 (Two storey building)** and **Section 9 (Three storey building)**.
- m) Selection of floor slab and staircase as per requirement (**Section 10**).
- n) Reinforcing of non-load-bearing walls (**Section 11**).
- o) Reinforcing of parapets (**Section 12**).

B Foundation

- a) Estimation of bearing capacity of soil for foundation. (**CI 3.3 to CI 3.5**)
- b) Determining foundation layout and type (Isolated or Eccentric) (**Section 8.1 and Section 9.1**)
- c) Design of foundation thickness against punching shear failure using IS 456:2000
- d) Design of foundation width against settlement and soil bearing capacity of soil.
- e) Selection of plan dimension of footing from foundation layout type and soil bearing capacity. (**Section 8.1 and Section 9.1**)
- f) Selection of reinforcement from respective footing (**Section 8.1 and Section 9.1**)

6.2 Seismic Base Shear Calculation from Equivalent Static Method

The structure shall be designed to withstand a total horizontal seismic base shear, V , calculated in accordance with the formula:

$$V = C_d(T_1) \times W$$

where,

W = seismic weight of the structure as per NBC 105:2020

$C_d(T_1)$ = $C(T_1)/R_\mu\Omega_u$, for ultimate limit state ($R_\mu=4$, $\Omega_u=1.5$ for Reinforced Concrete Moment Resisting Frame)

= $C_s(T_1)/\Omega_s$, for serviceability limit state ($\Omega_s=1.25$ for RC Moment Resisting Frame)

6.2.1 Elastic Site Spectra

$C(T)$ = $C_h(T) Z I$, for ultimate limit state

$C_s(T)$ = $0.20 C(T)$, for serviceability limit state

where,

$C_h(T)$ = spectral shape factor (**Figure 6-1**) which depends on the site subsoil condition (**Clause 6.2.2**) and time period of structure as per NBC 105:2020

Z = Seismic zoning factor (**ANNEX**)

I = Importance factor ($I=1$ for ordinary residential buildings)

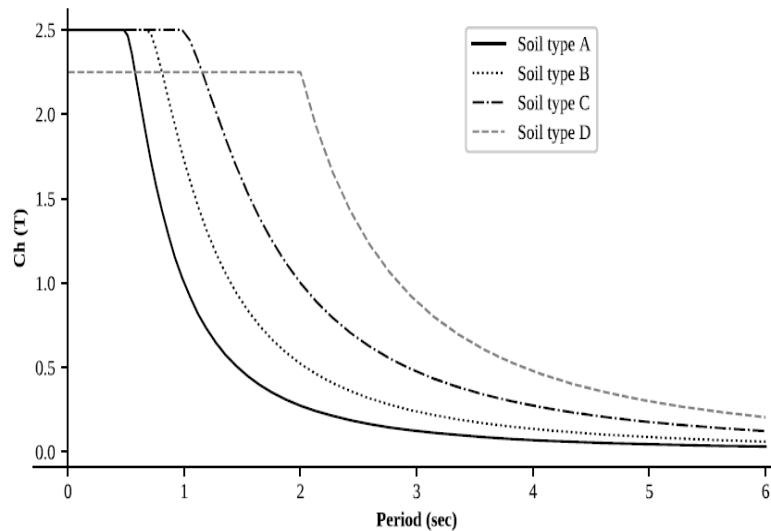


FIGURE 6-1 SPECTRAL SHAPE FACTOR, $C_h(T)$ FOR EQUIVALENT STATIC METHOD

(i) Time Period by Rayleigh Method

$$T_1 = 2\pi \sqrt{\frac{\sum_{i=1}^n (W_i d_i^2)}{g \sum_{i=1}^n (F_i d_i)}}$$

Where

d_i = elastic horizontal displacement of center of mass at level i , ignoring the effects of torsion.

F_i = lateral force acting at level i ,

g = acceleration due to gravity,
 i = level under consideration
 n = number of levels in the structure,
 W_i = seismic weight at level i

(i) Time Period by Empirical Method

$$T_1 = k_t h^{3/4}$$

Where

h = Height of the building from foundation or from top of a rigid basement.

k_t = 0.075 for Moment resisting concrete frame,

0.085 for Moment Resisting structural steel frame,

0.075 for Eccentrically braced structural steel frame,

0.05 for All other structural systems.

Amplification of approximate fundamental time period calculated using empirical equation shall be increased by factor of 1.25.

The amplified time period calculated from empirical method shall be compared with the translation time period computed from Rayleigh Method. For design action the lesser value of the two shall be adopted.

6.2.1 Site Subsoil Category

For the use for this RUD, the site subsoil is categorized into:

- i. Site Type C
- ii. Site Type D

TABLE 6-1 MUNICIPALITIES WITH SITE TYPE D

S. No.	Municipalities
1.	Kathmandu
2.	Lalitpur
3.	Bhaktapur
4.	Madhyapur Thimi
5.	Kageshori Manahara
6.	Tokha

For other municipalities other than mentioned in **Table 6-2**, site type C shall be adopted.

6.2.2 Seismic Zoning Factor (Z)

Seismic zoning factor for different Cities/Municipalities for use of this RUD is given in ANNEX.

6.3 Vertical Distribution of Total Horizontal Seismic Base Shear

The total horizontal base shear, V , shall be distributed up the height of the building in accordance with the formula (refer to **Figure 6-2**):

$$F_i = \frac{W_i h_i^k}{\sum_i^n W_i h_i^k} \times V$$

Where,

F_i the lateral seismic force induced at each level i .

W_i seismic weight of the structure assigned at level i .

h_i height (m) from the base to level i .

n total number of floors/level

V horizontal seismic base shear calculated as per section 6.2

k an exponent related to the structural period as follows:

- for structure having time period $T \leq 0.5$ sec, $k=1$
- for structure having time period $T \geq 2.5$ sec, $k=2$
- for structure having period between 0.5 sec and 2.5 sec, k shall be determined by linear interpolation between 1 and 2.

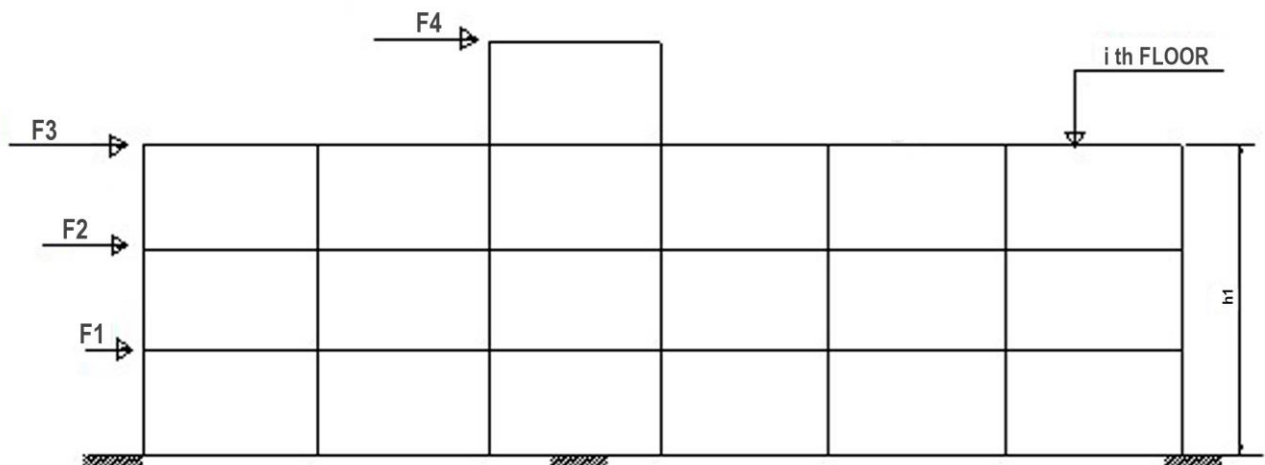


FIGURE 6-2 LATERAL SEISMIC FORCE INDUCED AT FLOOR LEVELS

6.4 Preparation of Numerical Model of Building

Three dimensional numerical bare frame model with rigid diaphragm is prepared; the seismic load evaluated in **Cl 6.3** is applied at C.G. of each storey with additional eccentricity as defined in NBC 105 :2020.

7. Design of the Frames

7.1 Preparation of Numerical Model of Building Frames

All frames are designed:

- (a) To support the applied vertical gravity loads (including the weight of the brick masonry walls) without assistance from the walls, and
- (b) For seismic condition using forces as per **Cl 6.3**.
- (c) Design Load combinations for dead load, live load and earthquake load as per NBC 105:2020.

7.2 Design

The members and joints is then designed and shall be detailed to achieve ductile deformations under severe earthquakes as per NBC 105:2020.

The recommendations for member sizes and minimum reinforcement in all components are presented in different section. For two storey building, **Section 8** shall be referred and for three storey building **Section 9** shall be adopted for respective seismic zone and site subsoil category. The reinforcement shall also comply with the respective applicable section.

7.2.1 Basis of Recommendations

Based on analysis and calculations of different models for different seismic zoning factor and site subsoil category(C & D) using the following data:

Building Occupancy	:	Residential
Column Plan Bay Dimension	:	3m to 4.5m
Bay Nos.	:	2 to 6 not Exceeding building coverage area as per Cl. 4.2
Number of Storeys	:	up to three storeys plus pent house (penthouse area not exceeding 25% of building plan area)
Storey Height	:	3.2 m (maximum storey heightnot exceeding total height 12 m) (Based upon architectural requirement, storey height can be decreased but shall comply with restriction as per Cl 4.2)
Plinth Level	:	450mm (maximum) above ground level.
Wall Thickness	:	half brick wall (or equivalent weight) for all internal walls and up to full brick wall (or equivalent weight) for all external walls
Staircase Wall	:	Staircase Perimeter Wall 9"
Cantilever Floor Projection	:	1.0 m (from centre-line of beam)
Concrete mix	:	M20 (1:1.5:3) (minimum compressive strength of cube at 28 days=20 N/mm ²)
Reinforcement	:	Fe500 (minimum yield strength = 500 N/mm ²)

Mortar	:	Minimum 1:4 cement-sand mortar for half-brick thick wall and 1:6 cement-sand mortar for full-brick thick
Bricks	:	Minimum compressive strength 3.5 N/mm ²

7.3 Foundation Design

The foundation design is designed using IS 456:2000 and detailed using SP 34 in conjunction with NBC 105:2020.

7.3.1 Basis of Recommendations

Footing Plan Layout	:	Isolated or one way Eccentric Isolated
Concrete mix	:	M20 (1:1.5:3) (minimum compressive strength of cube at 28 days = 20 N/mm ²)
Reinforcement	:	Fe500 (minimum yield strength = 500 N/mm ²)
Mortar	:	Minimum 1:4 cement-sand mortar for half-brick thick wall and 1:6 cement-sand mortar for full-brick thick
Bricks	:	Minimum compressive strength 3.5 N/mm ²

7.4 Recommended Members Sizes and Reinforcement

Foundation

Isolated

Thickness	:	350 mm / 400 mm
Width	:	As Shown in Table 8-1 to Table 8-3 and Table 9-1 to Table 9-3 .
Reinforcement	:	12 ϕ & 16 ϕ ((Fe 500) as shown in Figure 8-1 & Figure 9-1 .

Eccentric Footing

Thickness	:	350 mm / 400 mm
Width	:	As shown in Table 8-4 to Table 8-6 and Table 9-4 to Table 9-5 .
Reinforcement	:	12 ϕ & 16 ϕ as shown in Figure 8-2 & Figure 9-2

Strap Beam

Width	:	400 mm
Depth	:	450 mm
Reinforcement	:	16 ϕ ((Fe 500) as shown in Figure 8-2 (a & b) & Figure 9-2

Column

Width	:	350 mm / 400 mm
Depth	:	350 mm / 400 mm
Reinforcement	:	As shown in Figure 8-3 & Figure 9-3 .

Beam

Plinth beam (both directions)		
Width	:	250 mm

Depth : 355 mm
Floor beam (both directions)
Width : 250 / 300 mm (for first floor)
: 250 mm (for second/third floor and roof)
Depth : 355 / 380mm overall including slab (for first & second floor)
: 355 mm overall including slab (for third floor and roof)
Reinforcement : As shown in **Figure 8-3, Figure 8-4, Figure 9-4 & Figure 9-5**

Slab

Roof and Floors

Thickness : 125 mm (5")
Reinforcement : 8 ϕ (Fe 500) bars as shown in **Figure 10-1 and Figure 10-2**

Staircase

Waist Slab

Thickness : 150 mm (6")
Reinforcement : 12 ϕ longitudinal bars, 8 ϕ distribution bars as shown in
Figure 10-4 & Figure 10-5

[Note:

The minimum size of structural members and corresponding reinforcement shall not be limited to this standard if the building has been designed for site-specific condition provided that all the design and detailing requirements from NBC 105:2020 have been satisfied.]

8. Two Storey Building

8.1 Foundation

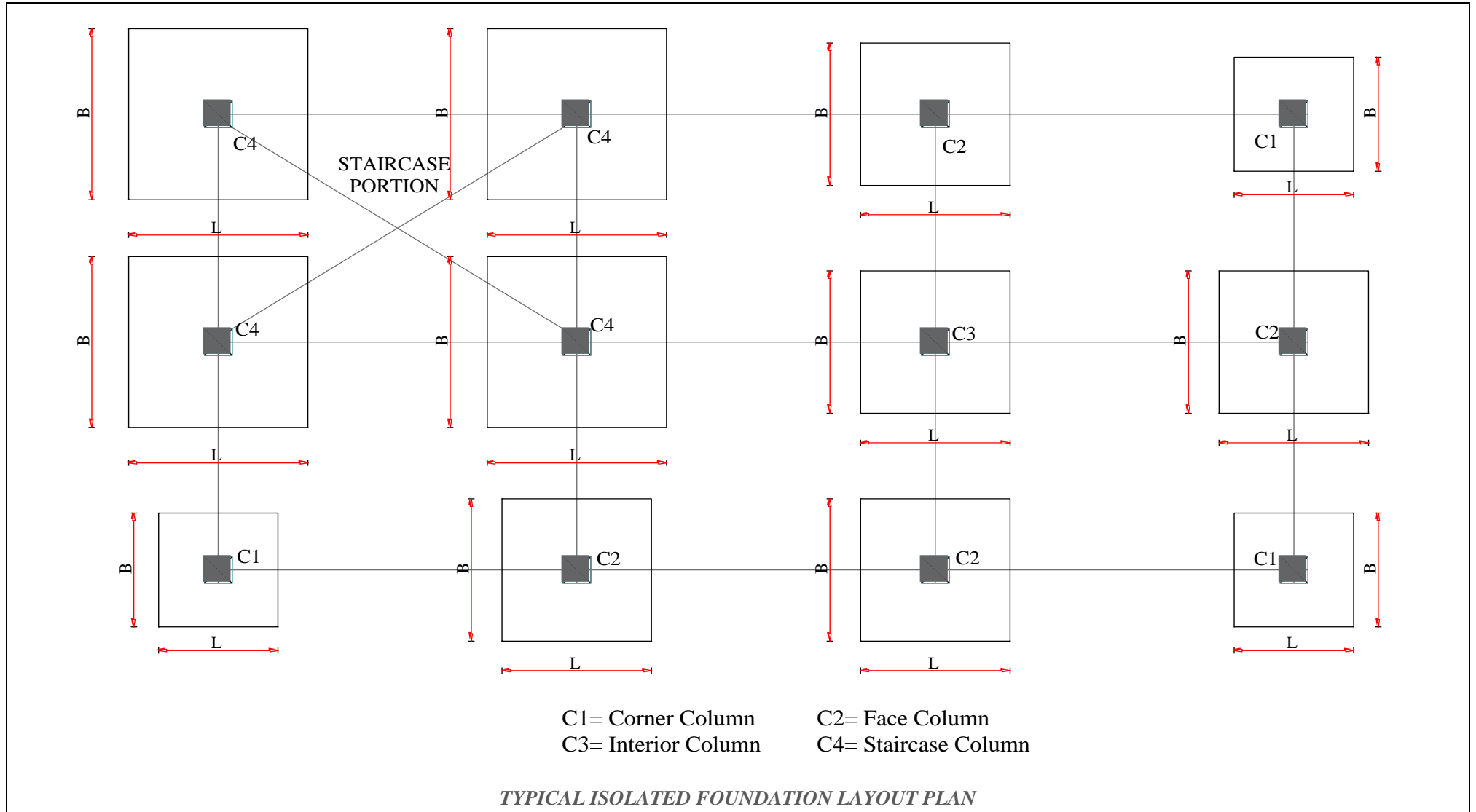
This section covers isolated footing and one-way eccentric isolated footing for two storey building and predetermined soil bearing capacity as presented in **CI 3.3 to CI 3.5**. Such footing shall rest on firm and well-compacted ground and shall not be constructed in areas as covered in **CI 3.1**.

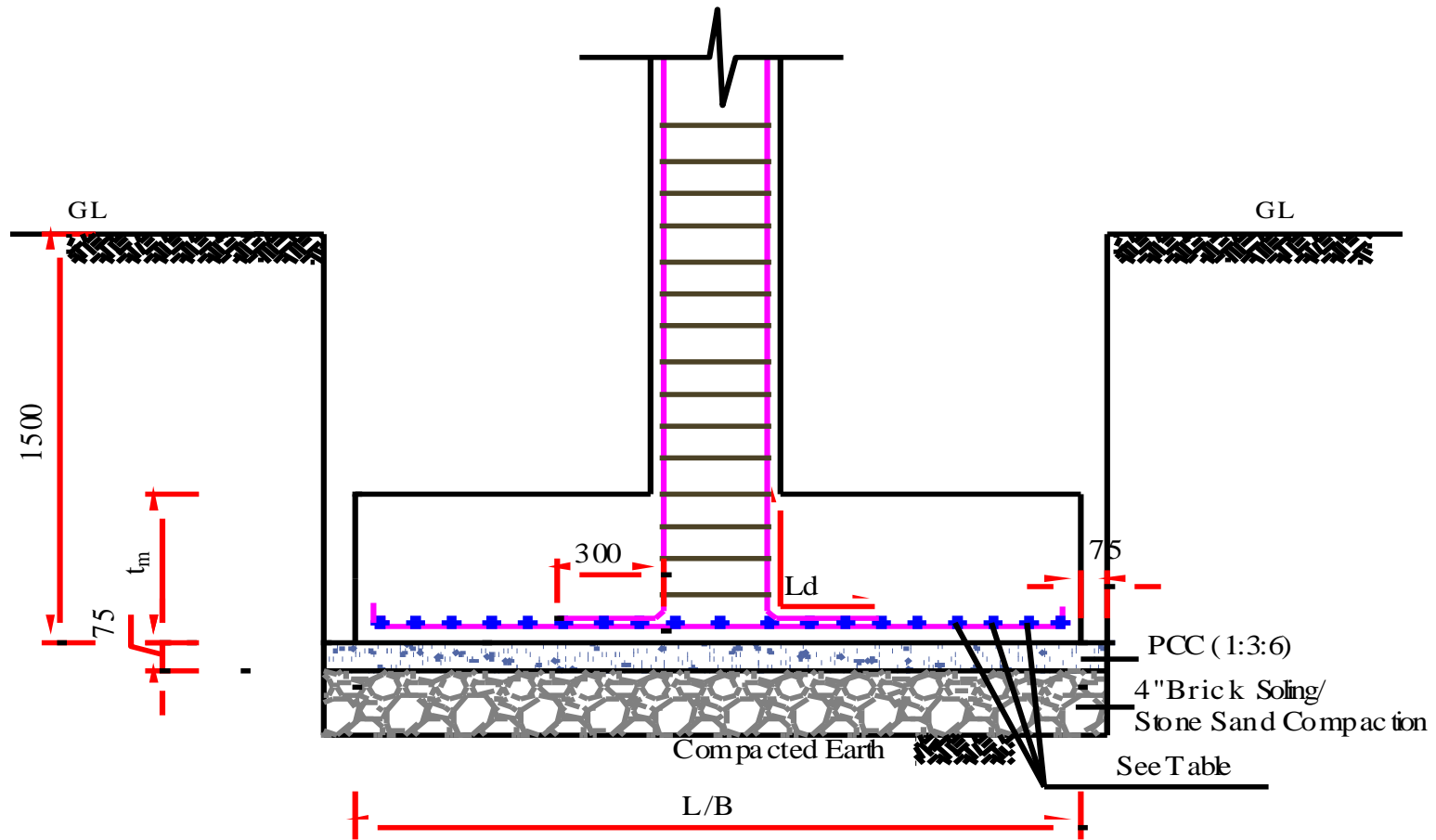
Combined Footing: When two or more adjacent footings overlap to form a combined footing, the footing shall be designed using professional engineering practice which is not covered by this RUD.

8.1.1 Isolated Footing

Isolated Footing: The sizes of isolated footing and corresponding reinforcement for two storey building with different soil bearing capacity (SBC) shall be adopted from **Table 8-1 to Table 8-3**. Details of isolated footing for two storey shall be as given in **Figure 8-1**. All plinth beams for two storey shall be constructed on a toe wall as shown in **Figure 8-1 and Figure 8-2**.

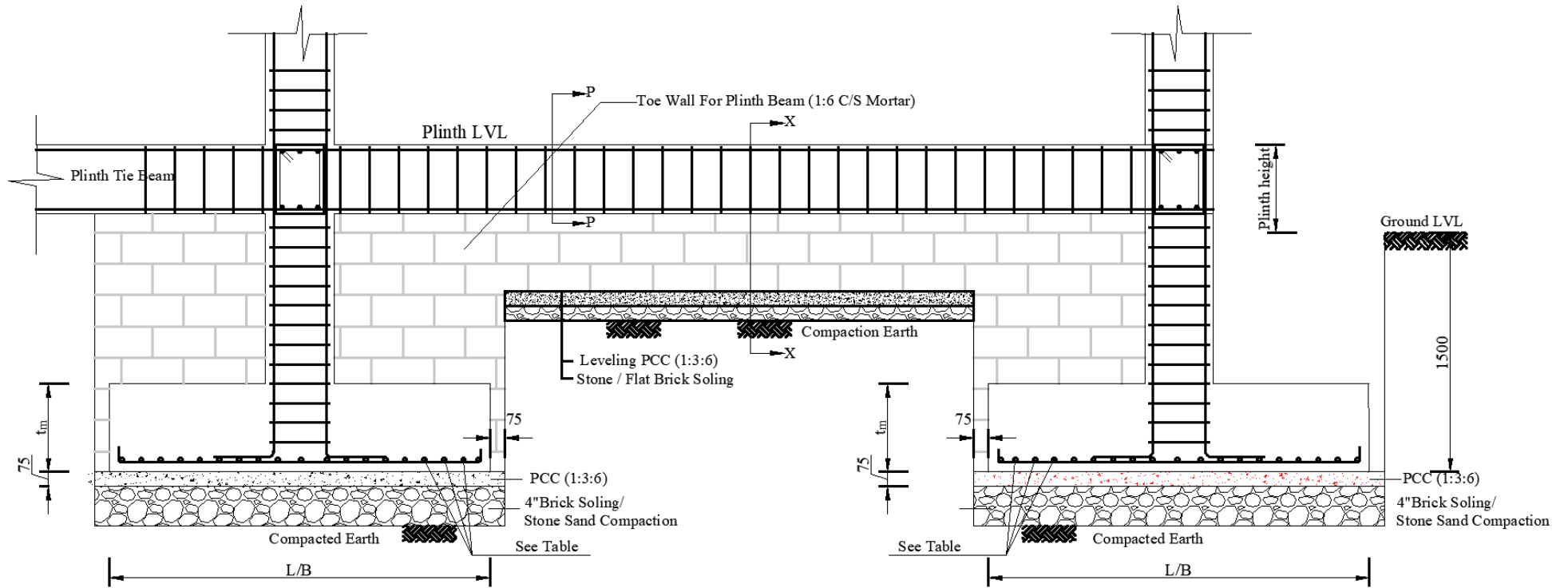
FIGURE 8-1 TYPICAL ISOLATED FOOTING DETAIL OF TWO STOREY BUILDING





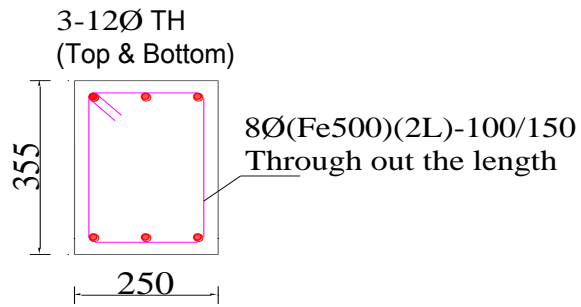
TYPICAL ISOLATED FOOTING SECTION
COVER FOR SIDE FACE = 75 MM; COVER FOR BOTTOM FACE = 50 MM

Note: Soiling with Brick (Brick Soiling) shall be not less than 4" and Soiling with Stone (Stone Soiling) shall be not less than 6"

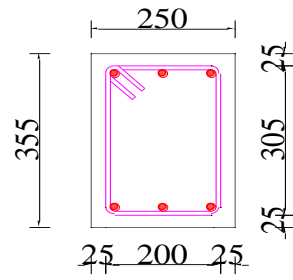


TYPICAL ISOLATED FOOTING, TOE WALL AND PLINTH TIE BEAM SECTION

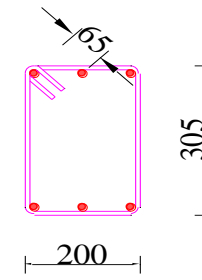
Note: Soiling with Brick (Brick Soiling) shall be not less than 4" and Soiling with Stone (Stone Soiling) shall be not less than 6"



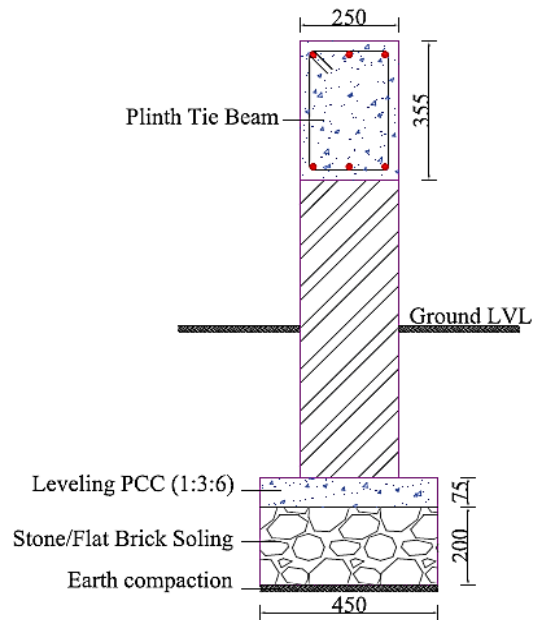
Plinth Tie Beam Section P-P



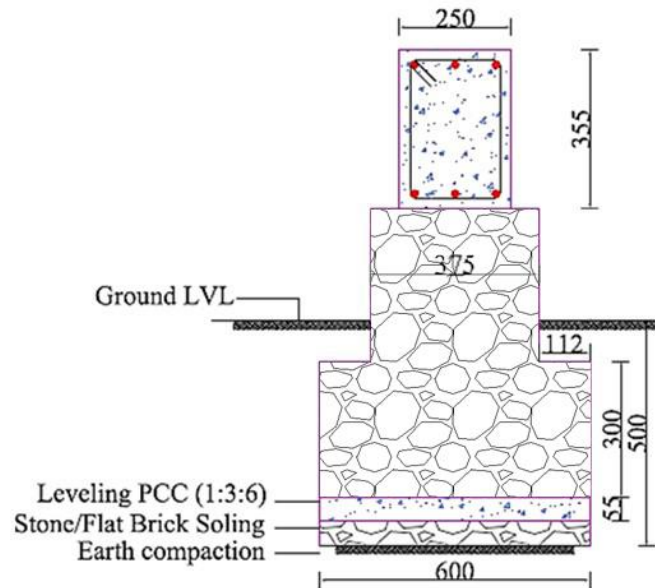
Typical Beam Section P-P



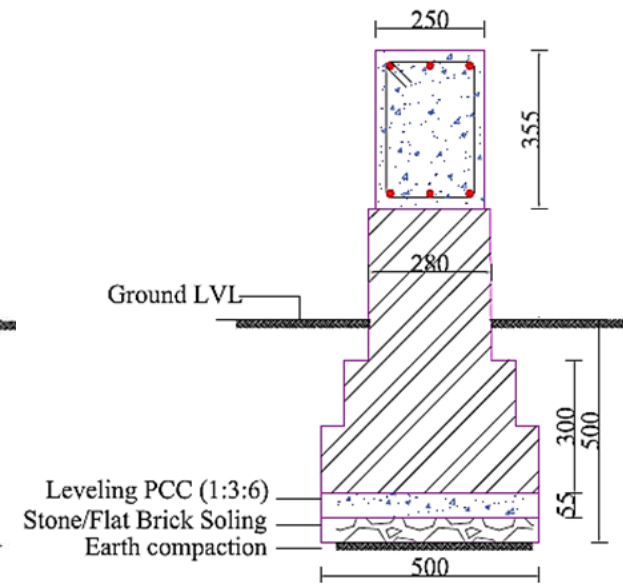
Size of Stirrups of dia 8mm



SECTION AT X-X



STONE MASONRY TOE WALL



BRICK MASONRY TOE WALL

**TABLE 8-1 ISOLATED FOOTING SIZE FOR TWO STOREY BUILDING
(SOIL BEARING CAPACITY= 200 KN/M²)**

Column Type	Foundation Plan, L=B (m)	Foundation Thickness, tm (mm)	Reinforcement Each Way
Corner	1.5	350	12Ø @150 mm c-c spacing
Face	1.5	350	12Ø @150 mm c-c spacing
Interior	1.5	350	12Ø @150 mm c-c spacing
Staircase	1.6	350	12Ø @100 mm c-c spacing

**TABLE 8-2 ISOLATED FOOTING SIZE FOR TWO STOREY BUILDING
(SOIL BEARING CAPACITY= 150 KN/M²)**

Column Type	Foundation Plan, L=B (m)	Foundation Thickness, tm (mm)	Reinforcement Each Way
Corner	1.5	350	12Ø @150 mm c-c spacing
Face	1.5	350	12Ø @150 mm c-c spacing
Interior	1.5	350	12Ø @150 mm c-c spacing
Staircase	1.85	350	12Ø @100 mm c-c spacing

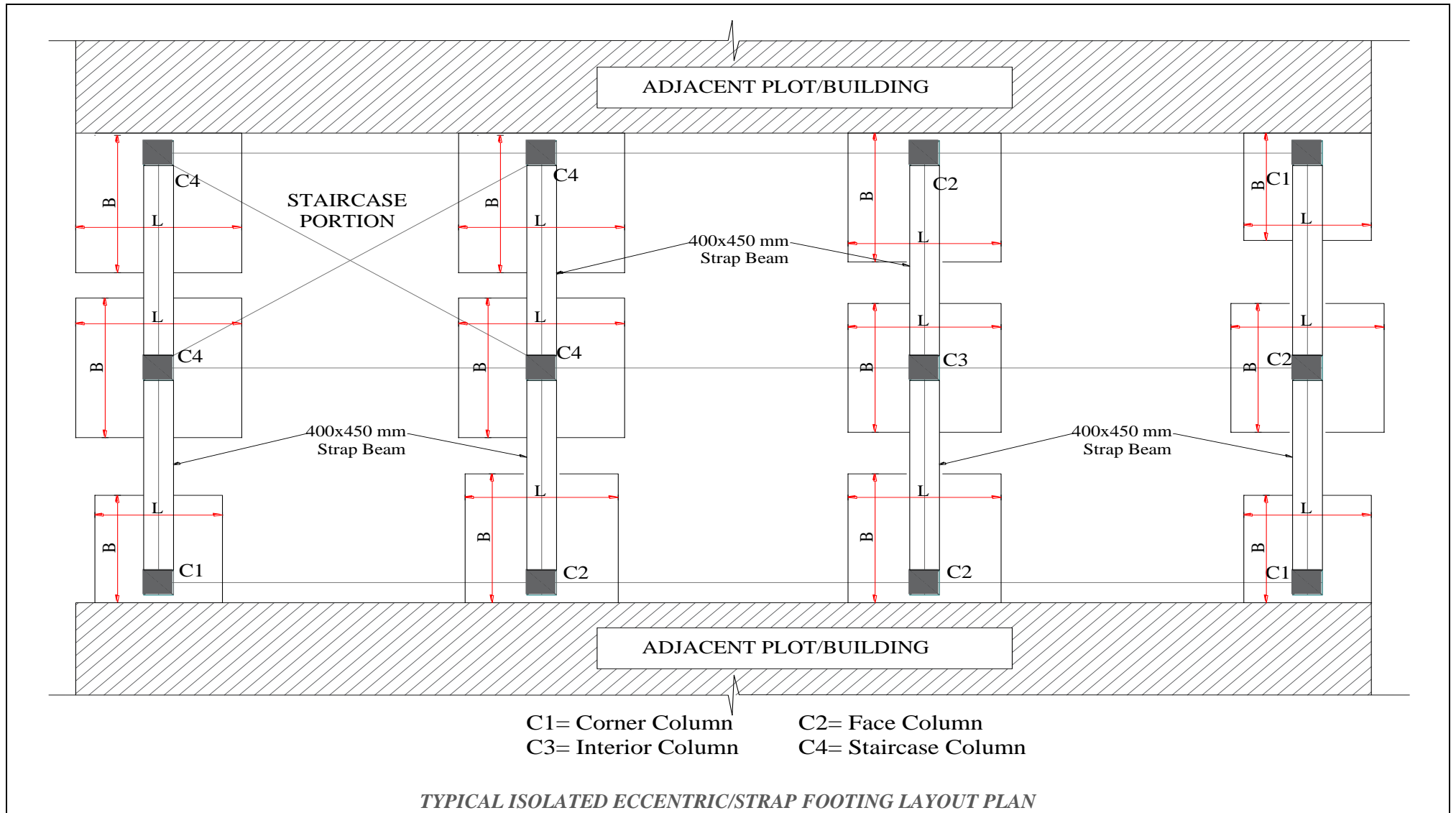
**TABLE 8-3 ISOLATED FOOTING SIZE FOR TWO STOREY BUILDING
(SOIL BEARING CAPACITY= 100 KN/M²)**

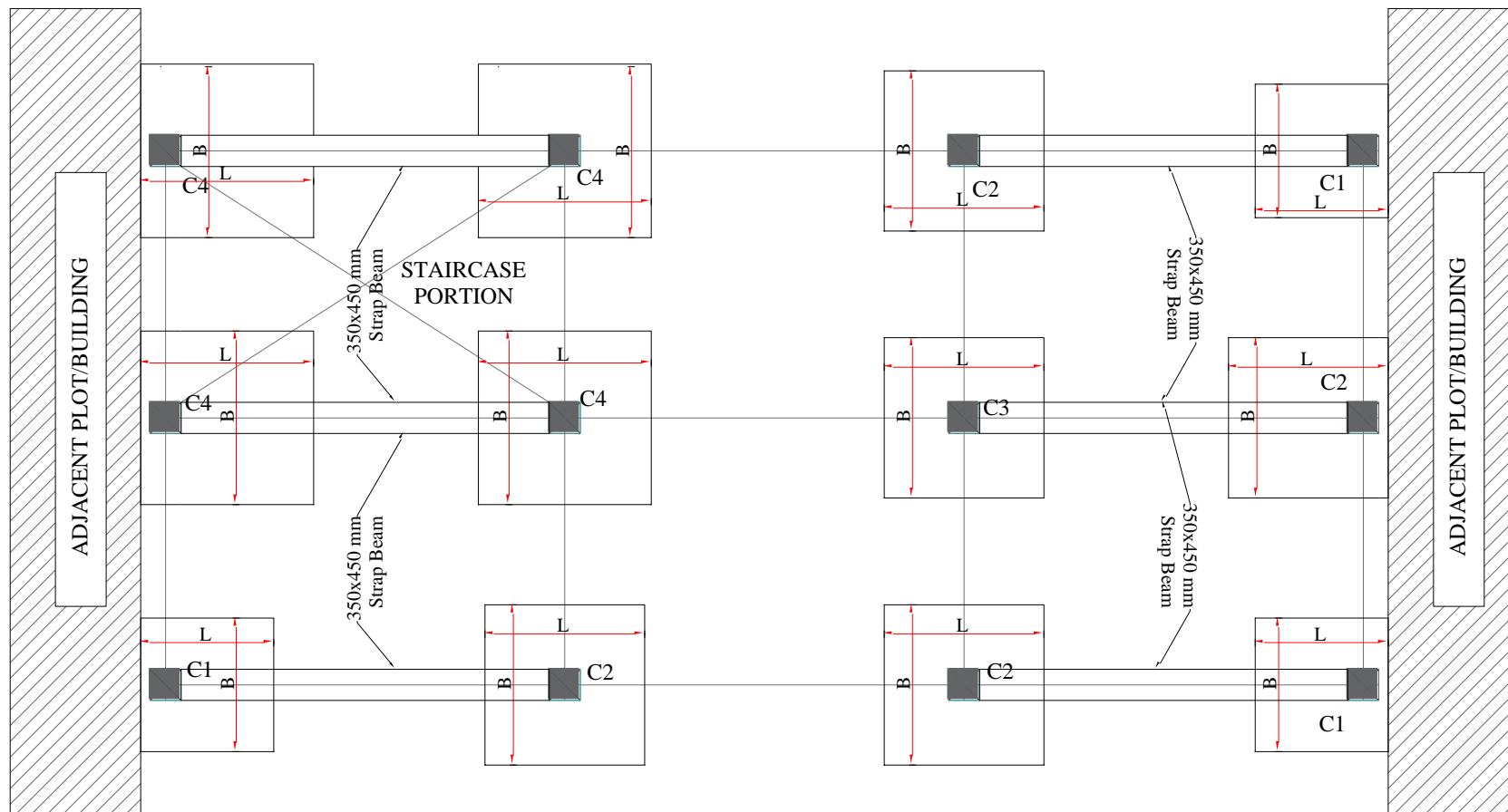
Column Type	Foundation Plan, L=B (m)	Foundation Thickness, tm (mm)	Reinforcement Each Way
Corner	1.5	350	12Ø @150 mm c-c spacing
Face	1.85	350	12Ø @150 mm c-c spacing
Interior	1.85	350	12Ø @150 mm c-c spacing
Staircase	2.3	350	12Ø @100 mm c-c spacing

8.1.1 Eccentric Isolated Footing

Eccentric Isolated Footing/Strap Footing: Footing shall be eccentric in one direction only as shown in **Figure 8-2** if it is required at site. Such eccentric footing for two storey building shall be accompanied by strap beam as shown in **Figure 8-2**. Similarly, for such eccentric footing, sizes and reinforcement arrangement shall be adopted from **Table 8-4** to **Table 8-6**. All plinth beams for two storey building shall be constructed on a toe wall as shown in **Figure 8-1** and **Figure 8-2**.

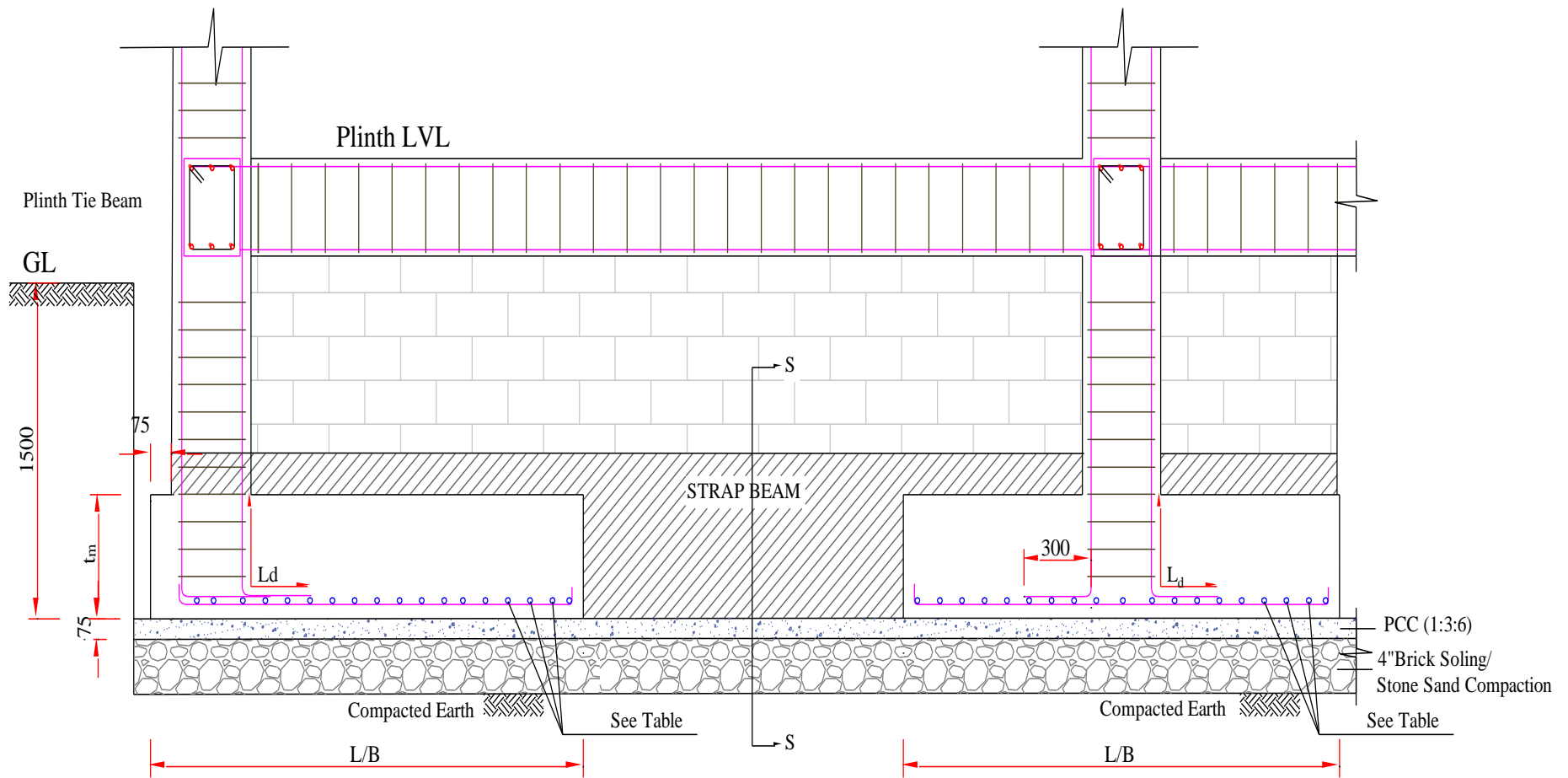
FIGURE 8-2 (A) TYPICAL ECCENTRIC FOOTING DETAIL





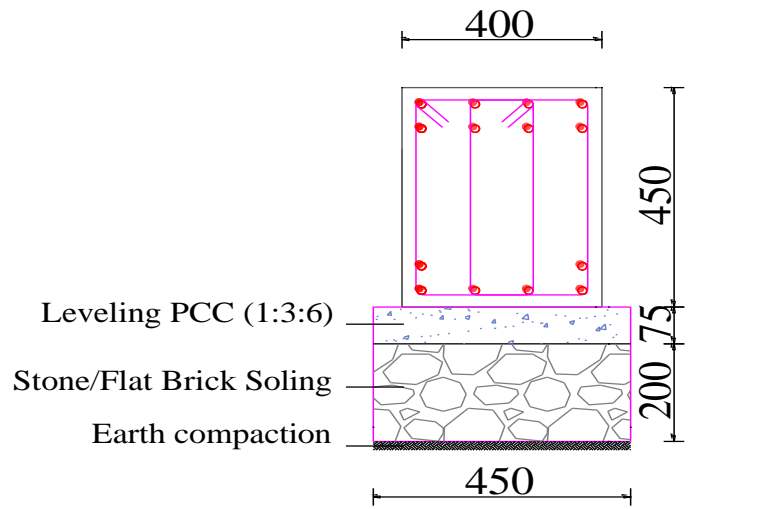
C1= Corner Column C2= Face Column
 C3= Interior Column C4= Staircase Column

TYPICAL ISOLATED ECCENTRIC/STRAP FOOTING LAYOUT PLAN

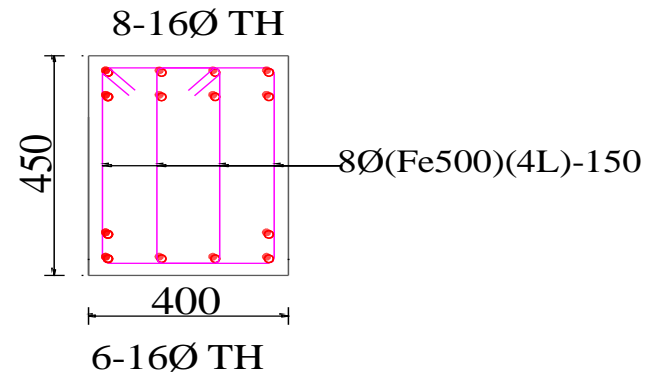


TYPICAL ISOLATED ECCENTRIC/STRAP FOOTING SECTION

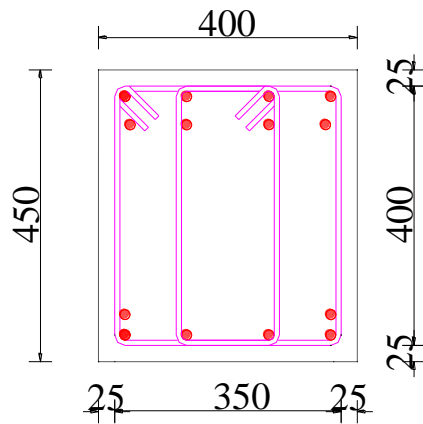
Note: Soiling with Brick (Brick Soiling) shall be not less than 4" and Soiling with Stone (Stone Soiling) shall be not less than 6"



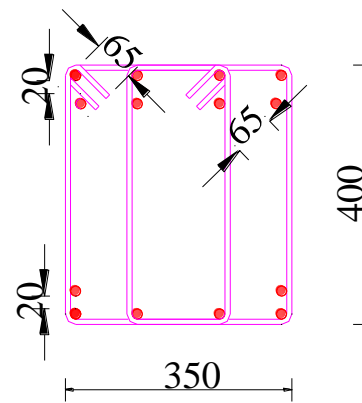
STRAP BEAM (SECTION S-S)



REBAR DETAIL IN STRAP BEAM



TYPICAL STRAP BEAM SECTION



SIZE OF STIRRUPS OF DIA 8MM

**TABLE 8-4 ECCENTRIC ISOLATED FOOTING SIZE FOR TWO STOREY BUILDING
(BEARING CAPACITY= 200 KN/M²)**

Column Type	Foundation Plan, L=B (m)	Foundation Thickness, tm (mm)	Reinforcement Each Way
Corner	1.5	350	12Ø @150 mm c-c spacing
Face	1.5	350	12Ø @150 mm c-c spacing
Interior	1.5	350	12Ø @150 mm c-c spacing
Staircase	1.6	350	12Ø @100 mm c-c spacing

**TABLE 8-5 ECCENTRIC ISOLATED FOOTING SIZE FOR TWO STOREY BUILDING
(BEARING CAPACITY= 150 KN/M²)**

Column Type	Foundation Plan, L=B (m)	Foundation Thickness, tm (mm)	Reinforcement Each Way
Corner	1.5	350	12Ø @150 mm c-c spacing
Face	1.5	350	12Ø @150 mm c-c spacing
Interior	1.5	350	12Ø @150 mm c-c spacing
Staircase	1.85	350	12Ø @100 mm c-c spacing

**TABLE 8-6 ECCENTRIC ISOLATED FOOTING SIZE FOR TWO STOREY BUILDING
(BEARING CAPACITY= 100 KN/M²)**

Column Type	Foundation Plan, L=B (m)	Foundation Thickness, tm (mm)	Reinforcement Each Way
Corner	1.6	350	12Ø @150 mm c-c spacing
Face	1.85	350	12Ø @150 mm c-c spacing
Interior	1.85	350	12Ø @150 mm c-c spacing
Staircase	2.5	350	12Ø @100 mm c-c spacing

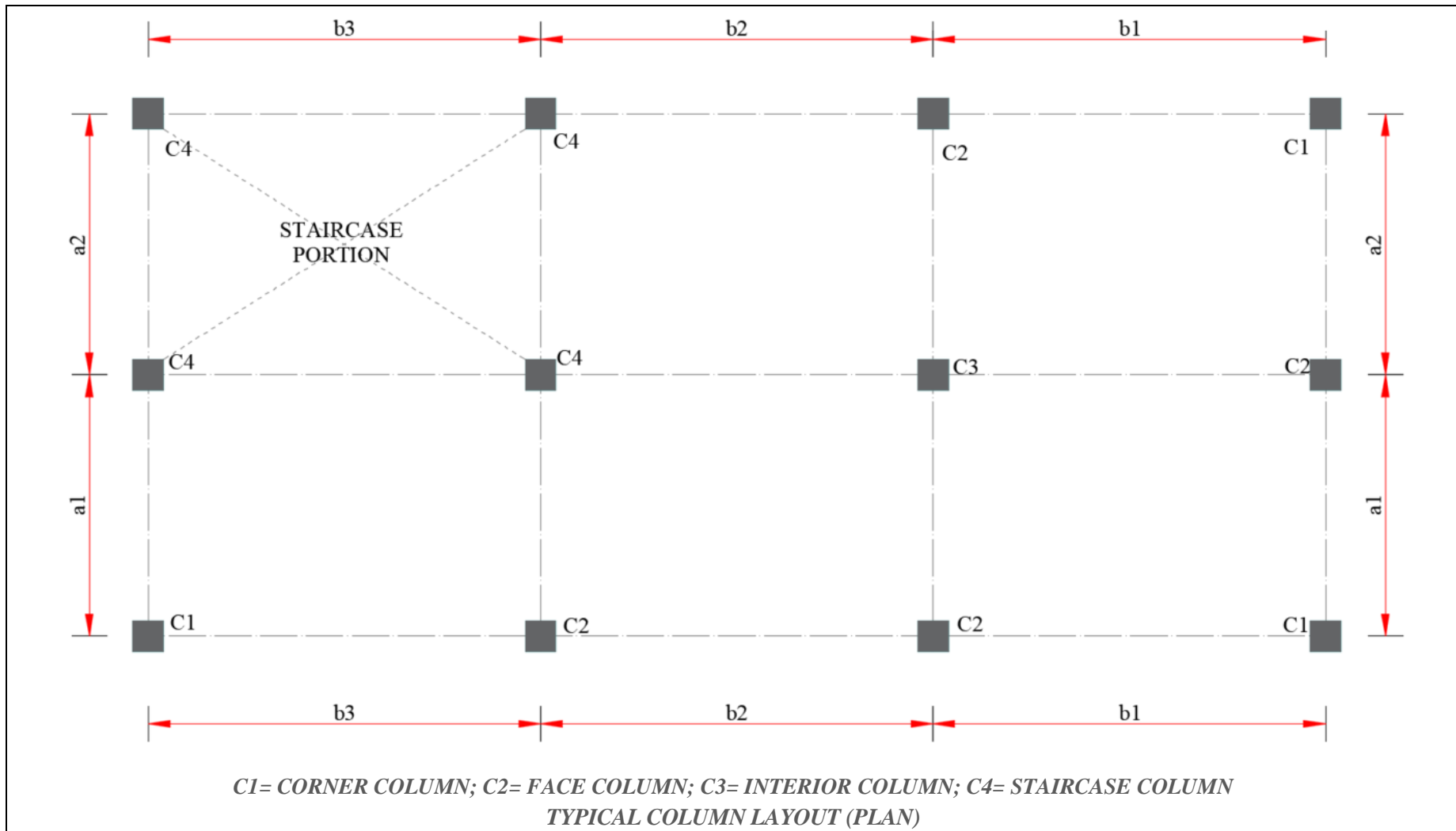
[Note:

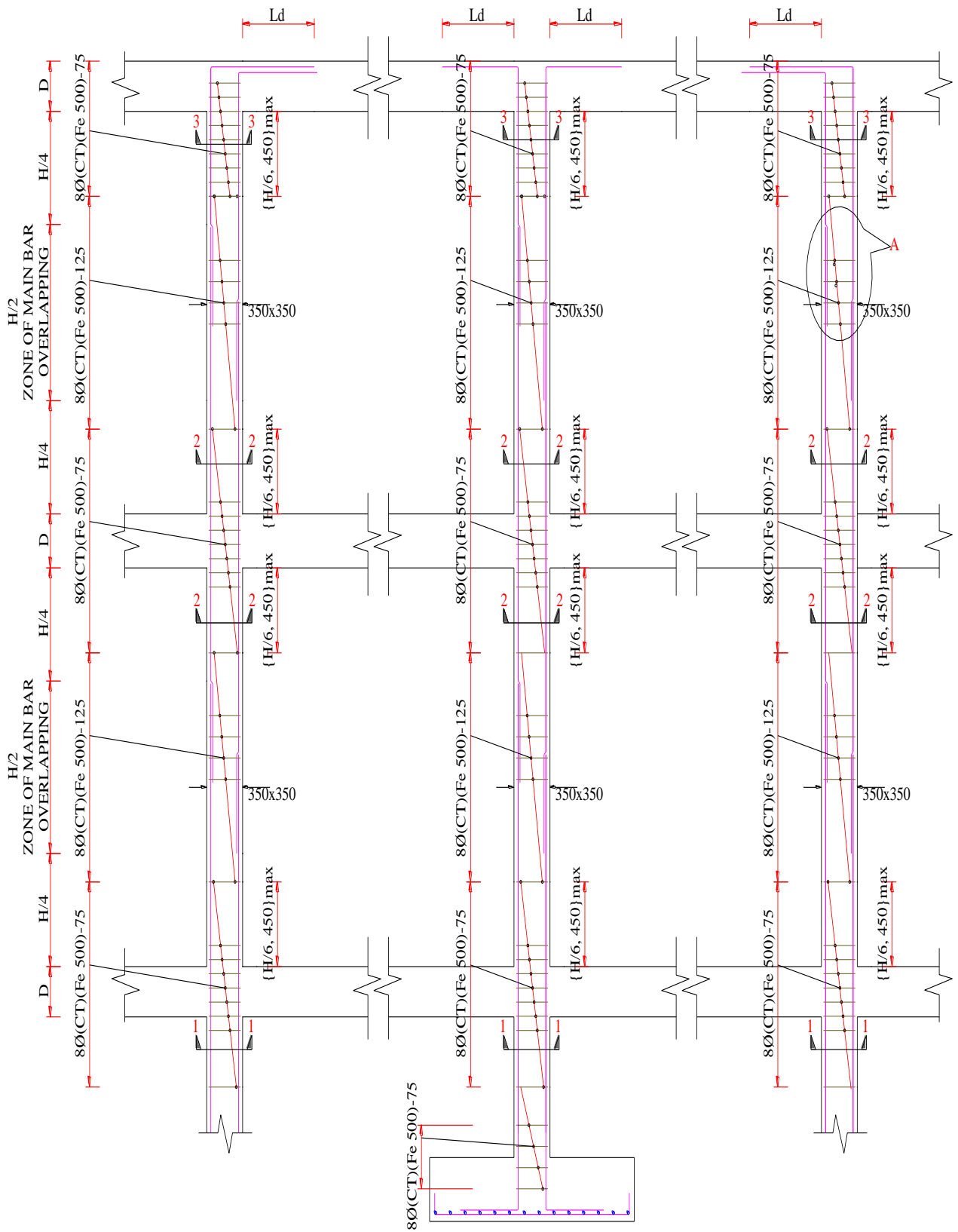
- i. Fe 500 (TMT) grade steel shall be used for all longitudinal reinforcements and stirrups/closed tie in beams and concrete grade shall be M20 for all footings and strap beams
- ii. Gravel packing is recommended to improve the soil bearing capacity of weak soil, however the footing size shall be adopted from **Table 8-1** to **Table 8-6**.
- iii. Eccentric footing shall be accompanied by strap beam whose size and reinforcement shall be adopted from **Figure 8-2**.
- iv. When more than two footing merge to form combine footing, the detail shall not be followed from this RUD and shall be designed using professional engineering practice
- v. Footing with dimension and SBC less than provided in **Table 8-1** to **Table 8-6**. due to site condition shall be designed using professional engineering practice.]

8.2 Column

This section covers size and reinforcement detail of column for two storey building with predetermined seismic zoning factor and site sub soil condition.

FIGURE 8-3 TYPICAL DETAIL OF COLUMN FOR TWO STOREY BUILDING





LAPPING IN COLUMN (TWO STOREY BUILDING)
SECTION THROUGH INTERIOR FRAME

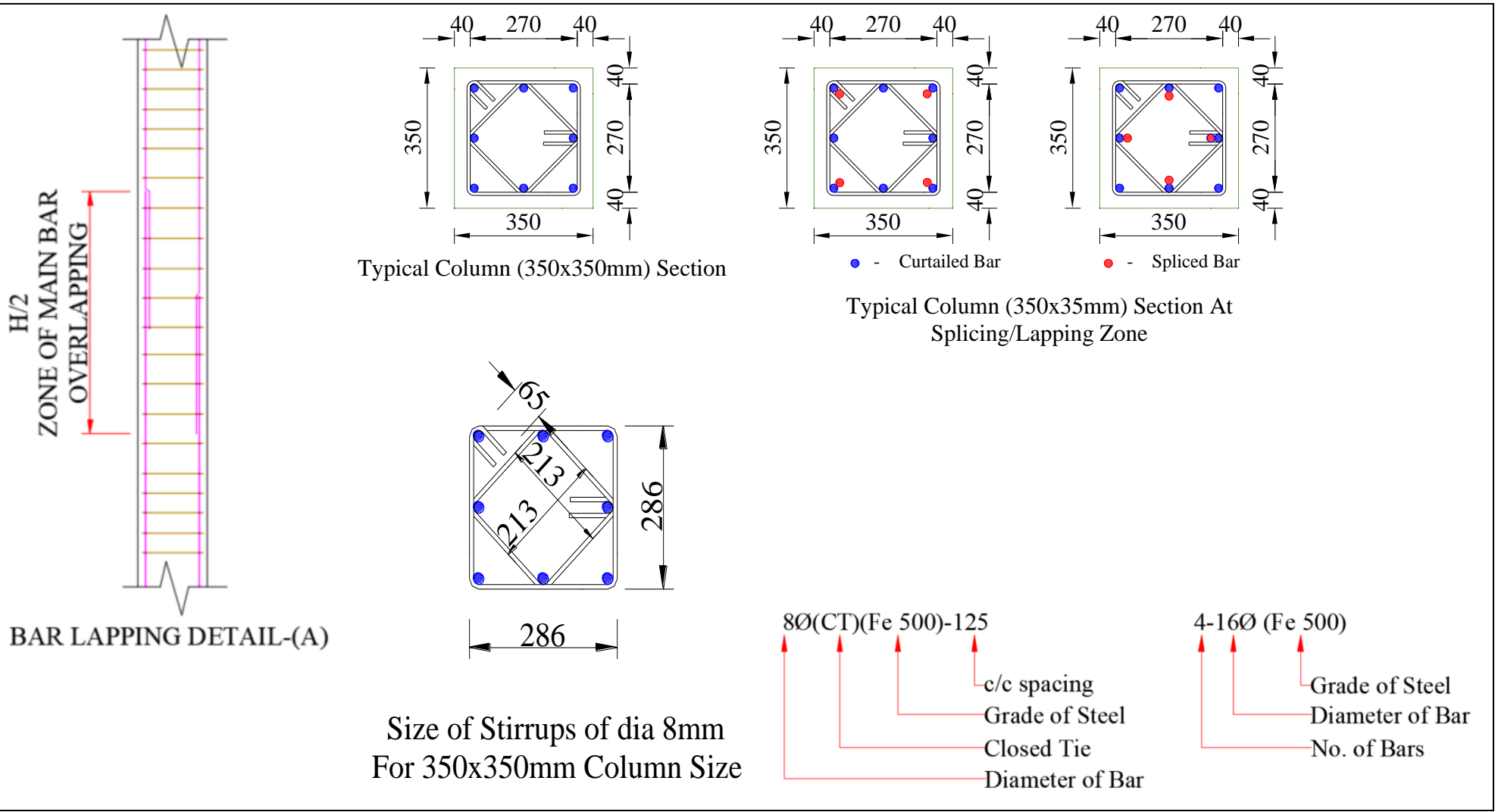


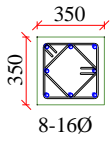
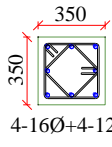
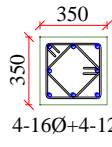
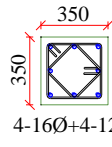

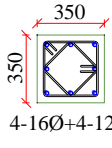
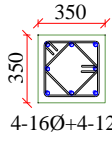
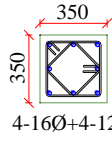
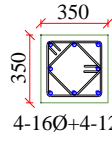
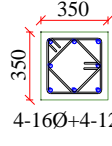
TABLE 8-7 REINFORCEMENT ARRANGEMENT OF COLUMN (350MM X350MM)FOR DIFFERENT REBAR COMBINATION OF THREE STOREY BUILDING

ARRANGEMENT OF 8 NUMBERS OF REBAR IN COLUMN				
S.NO.	COLUMN REBAR CONFIGURATION	REBAR COMBINATION	BAR SIZE 'a' (mm)	BAR SIZE 'b' (mm)
1		8-20Ø	20Ø	20Ø
2		4-20Ø+4-16Ø	20Ø	16Ø
3		8-16Ø	16Ø	16Ø
4		4-16Ø+4-12Ø	16Ø	12Ø

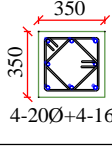
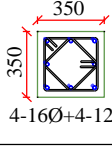
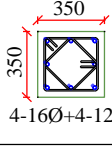
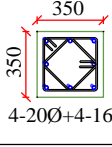

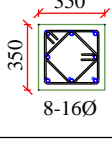
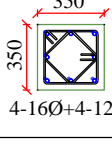
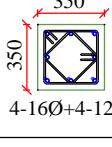
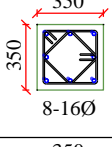
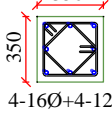
TABLE 8-8 COLUMN REINFORCEMENT DETAILS OF TWO STOREY BUILDING FOR DIFFERENT SEISMIC ZONES FOR SITE SUB SOIL CATEGORY C

COLUMN REINFORCEMENT DETAIL FOR TWO STOREY BUILDING; SEISMIC ZONE FACTOR= 0.25 CONCRETE GRADE= M20; STEEL GRADE=Fe 500 (TMT)						
SITE TYPE C	COLUMN LOCATION	CORNER (C1)	FACE (C2)	INTERIOR (C3)	STAIRCASE (C4)	STIRRUPS (ALL FLOOR)
	GROUND FLOOR	 4-16Ø+4-12Ø	 4-16Ø+4-12Ø	 4-16Ø+4-12Ø	 4-16Ø+4-12Ø	 8Ø@ 75 /125 mm c/c
	FIRST FLOOR	 4-16Ø+4-12Ø	 4-16Ø+4-12Ø	 4-16Ø+4-12Ø	 4-16Ø+4-12Ø	
	STAIRCOVER	—	—	—	 4-16Ø+4-12Ø	

**COLUMN REINFORCEMENT DETAIL FOR TWO STOREY BUILDING;
SEISMIC ZONE FACTOR= 0.3
CONCRETE GRADE= M20; STEEL GRADE=Fe 500 (TMT)**

SITE TYPE C	COLUMN LOCATION	CORNER (C1)	FACE (C2)	INTERIOR (C3)	STAIRCASE (C4)	STIRRUPS (ALL FLOOR)
	GROUND FLOOR	 350 350 8-16Ø	 350 350 4-16Ø+4-12Ø	 350 350 4-16Ø+4-12Ø	 350 350 4-16Ø+4-12Ø	 8Ø@ 75 /125 mm c/c
	FIRST FLOOR	 350 350 4-16Ø+4-12Ø	 350 350 4-16Ø+4-12Ø	 350 350 4-16Ø+4-12Ø	 350 350 4-16Ø+4-12Ø	
	STAIRCOVER	—	—	—	 350 350 4-16Ø+4-12Ø	

**COLUMN REINFORCEMENT DETAIL FOR TWO STOREY BUILDING;
SEISMIC ZONE FACTOR= 0.35
CONCRETE GRADE= M20; STEEL GRADE=Fe 500 (TMT)**

SITE TYPE C	COLUMN LOCATION	CORNER (C1)	FACE (C2)	INTERIOR (C3)	STAIRCASE (C4)	STIRRUPS (ALL FLOOR)
	GROUND FLOOR	 350 350 4-20Ø+4-16Ø	 350 350 4-16Ø+4-12Ø	 350 350 4-16Ø+4-12Ø	 350 350 4-20Ø+4-16Ø	 8Ø@ 75 /125 mm c/c
	FIRST FLOOR	 350 350 8-16Ø	 350 350 4-16Ø+4-12Ø	 350 350 4-16Ø+4-12Ø	 350 350 8-16Ø	
	STAIRCOVER	—	—	—	 350 350 4-16Ø+4-12Ø	

COLUMN REINFORCEMENT DETAIL FOR TWO STOREY BUILDING; SEISMIC ZONE FACTOR= 0.4 CONCRETE GRADE= M20; STEEL GRADE=Fe 500 (TMT)						
SITE TYPE C	COLUMN LOCATION	CORNER (C1)	FACE (C2)	INTERIOR (C3)	STAIRCASE (C4)	STIRRUPS (ALL FLOOR)
	GROUND FLOOR	 350 350 4-20Ø+4-16Ø	 350 350 8-16Ø	 350 350 4-16Ø+4-12Ø	 350 350 4-20Ø+4-16Ø	 8Ø@ 75 /125 mm c/c
	FIRST FLOOR	 350 350 8-16Ø	 350 350 4-16Ø+4-12Ø	 350 350 4-16Ø+4-12Ø	 350 350 8-16Ø	
	STAIRCOVER	—	—	—	 350 350 4-16Ø+4-12Ø	

TABLE 8-9 COLUMN REINFORCEMENT DETAILS OF TWO STOREY BUILDING FOR 0.35 SEISMIC ZONE FOR SITE SUB SOIL CATEGORY D

COLUMN REINFORCEMENT DETAIL FOR TWO STOREY BUILDING; SEISMIC ZONE FACTOR= 0.35 CONCRETE GRADE= M20; STEEL GRADE=Fe 500 (TMT)						
SITE TYPE D	COLUMN LOCATION	CORNER (C1)	FACE (C2)	INTERIOR (C3)	STAIRCASE (C4)	STIRRUPS (ALL FLOOR)
	GROUND FLOOR	 350 350 8-16Ø	 350 350 4-16Ø+4-12Ø	 350 350 4-16Ø+4-12Ø	 350 350 8-16Ø	 8Ø@ 75 /125 mm c/c
	FIRST FLOOR	 350 350 4-16Ø+4-12Ø	 350 350 4-16Ø+4-12Ø	 350 350 4-16Ø+4-12Ø	 350 350 4-16Ø+4-12Ø	
	STAIRCOVER	—	—	—	 350 350 4-16Ø+4-12Ø	

[Note:

- i. Fe 500 (TMT) grade steel shall be used for all longitudinal reinforcements and stirrups/closed tie and concrete grade shall be M20 for all columns.
- ii. Clear cover to stirrups should be 40mm.
- iii. Column sizes and respective reinforcement details for pre-determined seismic zone and site subsoil category according to two storey building shall be adopted from **Table 8-8 & Table 8-9**.
- iv. Reinforcement arrangement and stirrups sizes in column for two storey building for

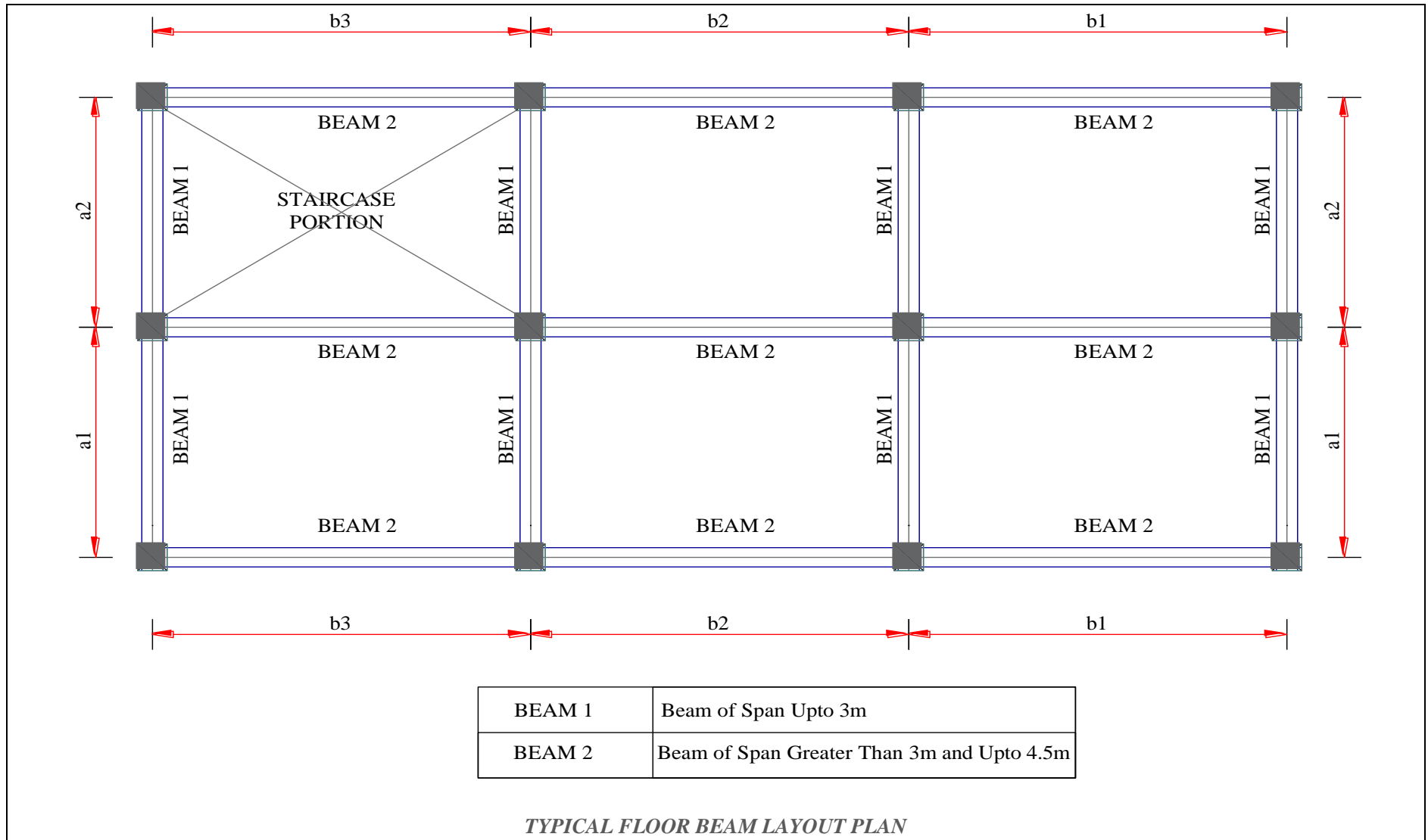
*respective column sizes shall be adopted **Figure 8-3.***

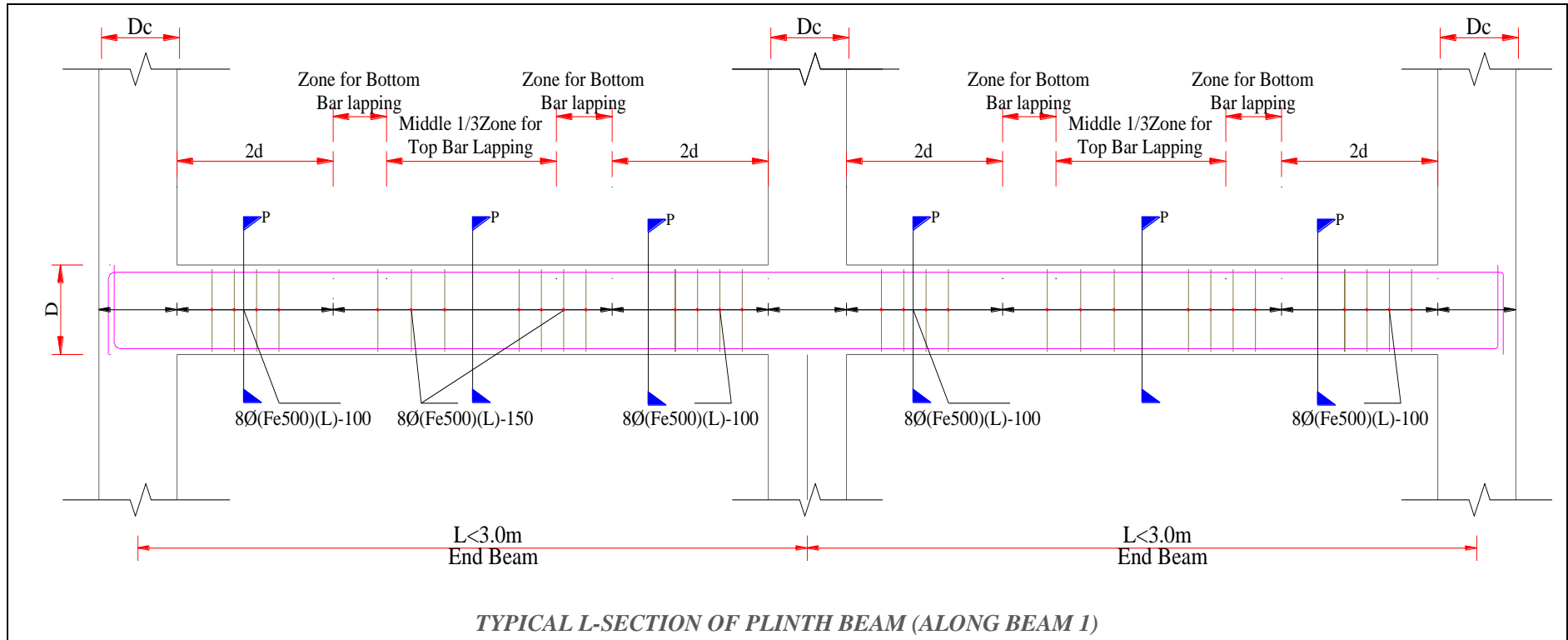
- v. *Splicing of longitudinal bar shall be allowed only in the zone shown in **Figure 8-3** and not more than 50% of the bars should be spliced at a section.*
- vi. *Lapping of bars should not be less than 57ϕ or as in **Table 9-10.***
- vii. *Transverse stirrups in columns shall be adopted from **Table 9-9.***

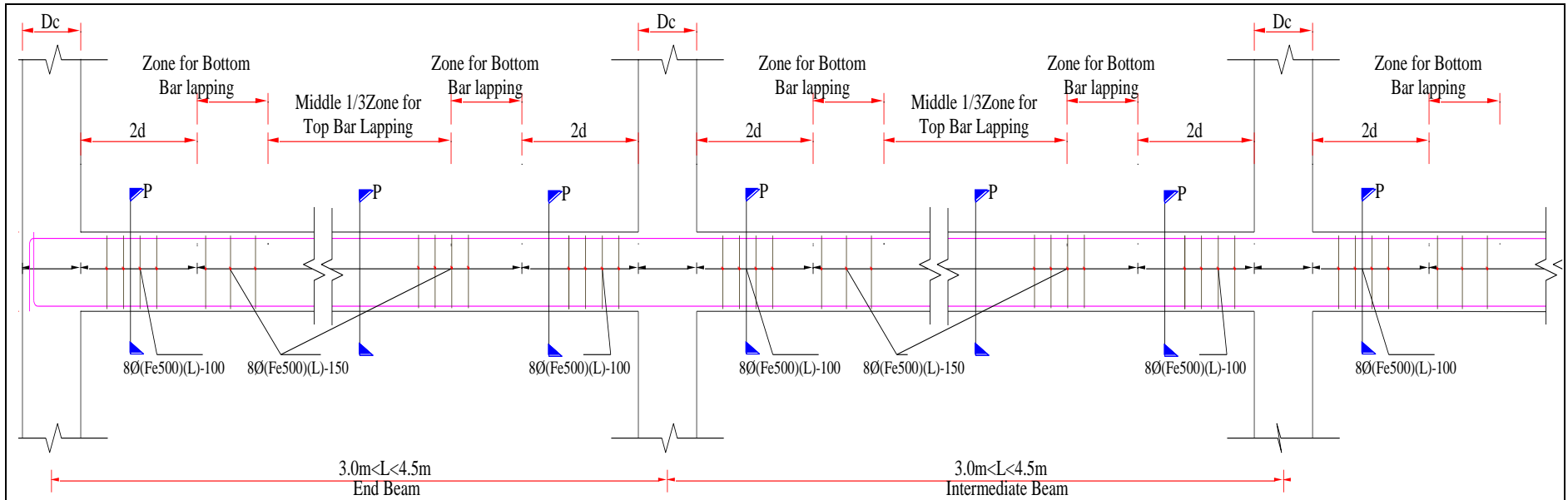
8.3 Beam

This section covers size and reinforcement detail of beam for two storey building with predetermined seismic zoning factor and site sub soil condition.

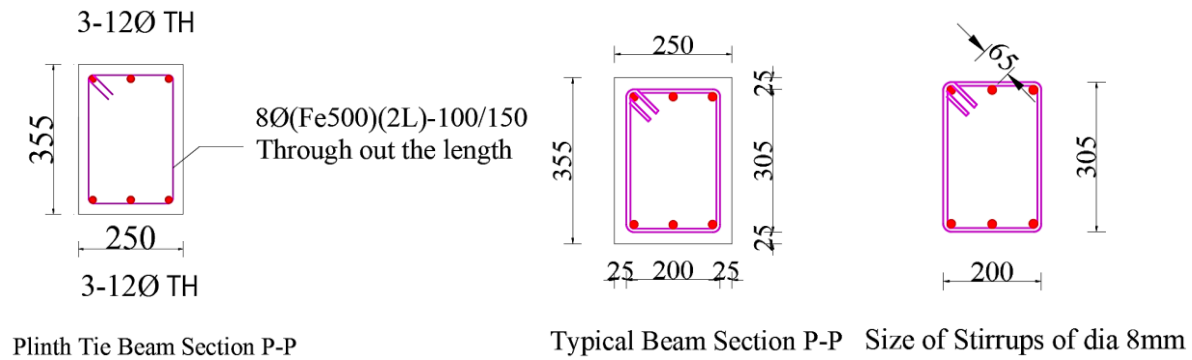
FIGURE 8-4 TYPICAL FLOOR BEAM DETAIL OF TWO STOREY BUILDING



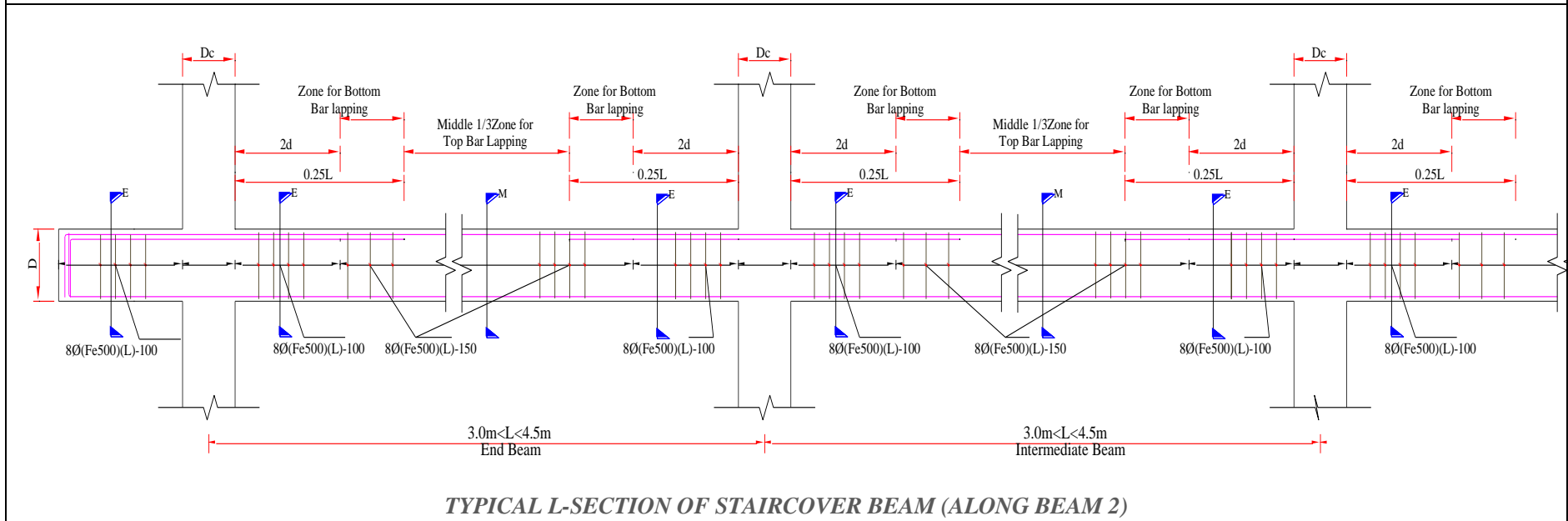
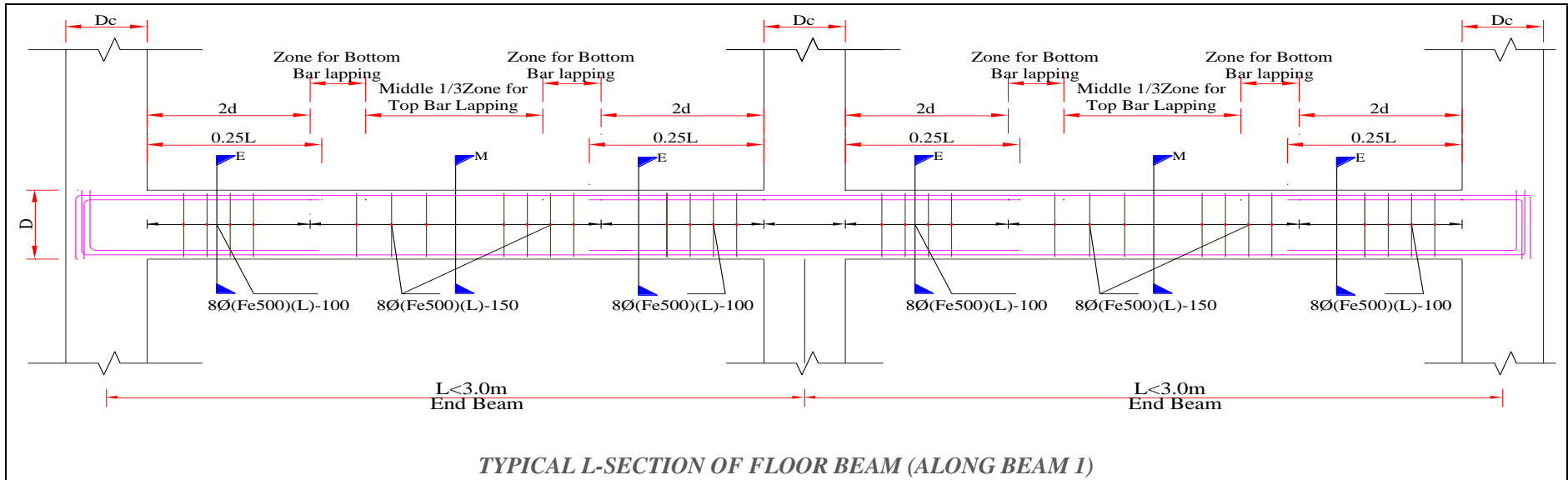


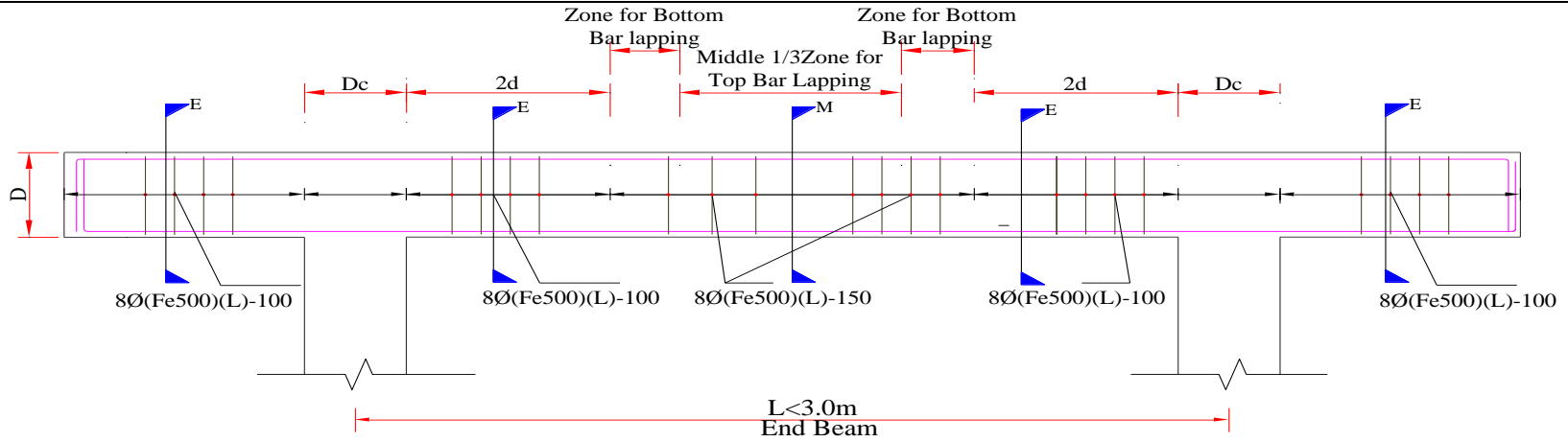


TYPICAL L-SECTION OF PLINTH BEAM (ALONG BEAM 2)

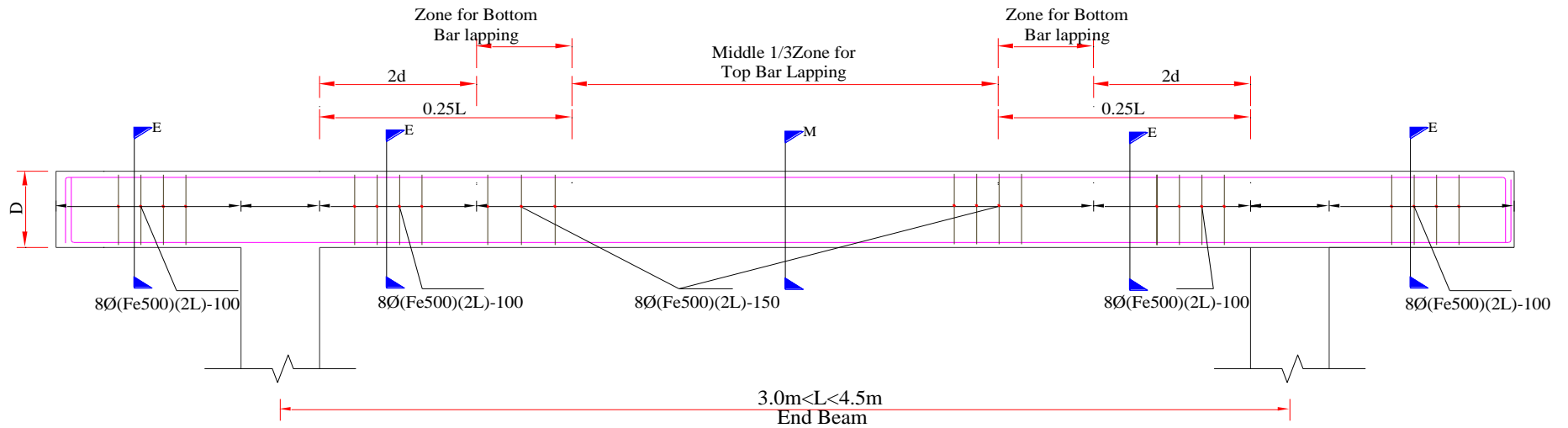


CROSS-SECTION DETAIL OF PLINTH BEAM





TYPICAL L-SECTION OF STAIRCOVER BEAM (ALONG BEAM 1)



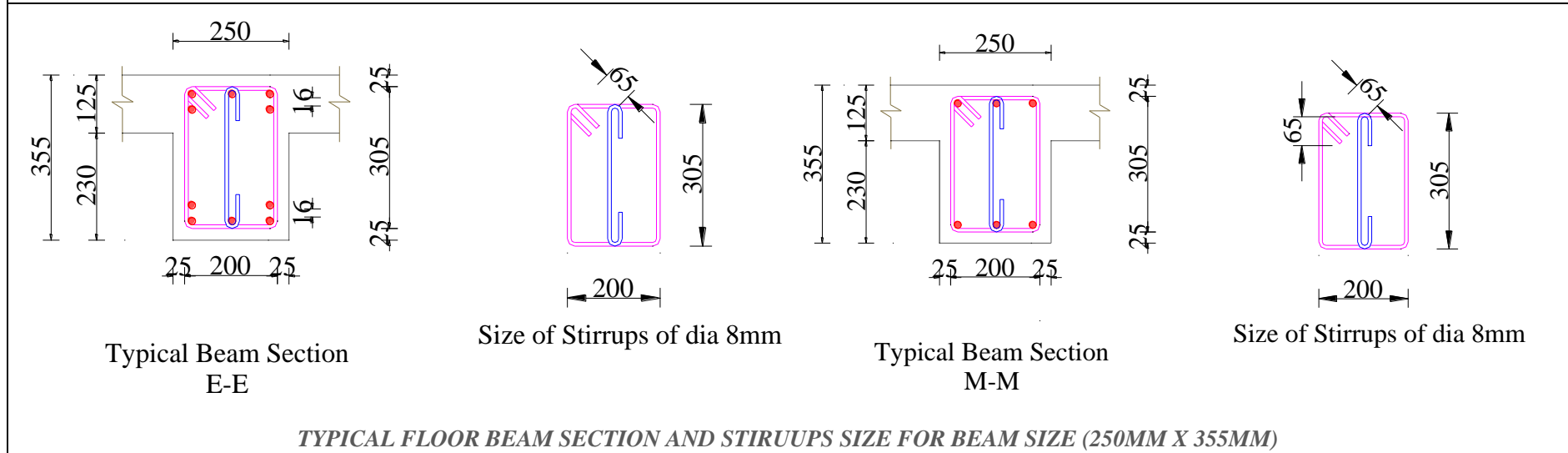
TYPICAL L-SECTION OF STAIRCOVER BEAM (ALONG BEAM 2)

FIGURE 8-5 REINFORCEMENT DISTRIBUTION IN FLOOR BEAM OF TWO STOREY BUILDING

<u>BEAM WIDTH (B) MM</u>	<u>BEAM DEPTH (D) MM</u>	<u>REBAR DISTRIBUTION OF BEAM AT MIDDLE BEAM SECTION (M)</u>	<u>REBAR DISTRIBUTION OF BEAM AT LEFT END/RIGHT END (E)</u>
250	355	<p>Through Bars (TH) At Top Face 8Ø(Fe500)(L)-100/150 Through Bars (TH) At Bottom Face</p>	<p>Through Bars (TH) At Top Face Extra Bars (EXT) At Top Face 8Ø(Fe500)(L)-100 Extra Bars (EXT) At Bottom Face Through Bars (TH) At Bottom Face</p>

TYPICAL FLOOR BEAM SECTION AND STIRRUPS SIZE FOR BEAM SIZE (250MM X 355MM)

NOTE: EXTRA BARS MAY NOT BE PROVIDED WHEREVER IT IS NOT NECESSARY AS PER BEAM REINFORCEMENT TABLE



NOTE: EXTRA BARS MAY NOT BE PROVIDED WHEREVER IT IS NOT NECESSARY AS PER BEAM REINFORCEMENT TABLE

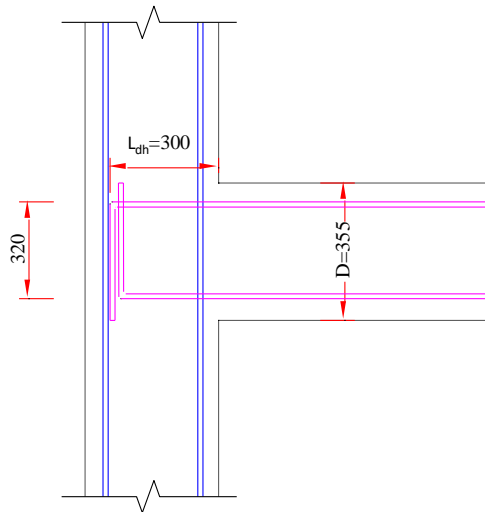
8Ø(Fe500)(L)-100

↑ ↑ ↑ ↑

c/c spacing
Nos of Legs
(Refer Transverse Rebar Table)

Grade of Steel
Diameter of Bar

FIGURE 8-6 ANCHORAGE OF LONGITUDINAL BARS OF BEAM IN COLUMN



ANCHORAGE OF LONGITUDINAL BARS OF BEAM (DEPTH = 355MM) IN COLUMN

TABLE 8-10 BEAM REINFORCEMENT DISTRIBUTION OF TWO STOREY BUILDING FOR DIFFERENT SEISMIC ZONES AND SITE SUB SOIL CATEGORY C

BEAM REBAR DISTRIBUTION TABLE FOR TWO STOREY BUILDING, SEISMIC ZONE FACTOR = 0.25									
SITE SUBSOIL CATEGORY C	FLOOR	Type	Beam Size		Face	Rebar Combination At Left End/ Right End(E)		Rebar Combination At Middle (M)	
			B(mm)	D(mm)		Through Bar (TH)	Extra Bars (EXT)	Through Bar (TH)	
	FIRST FLOOR	BEAM 1		250	355	Top	3-12Ø (T/O)	-	3-12Ø (T/O)
				250	355	Bottom	3-12Ø (T/O)	-	3-12Ø (T/O)
		BEAM 2		250	355	Top	3-12Ø (T/O)	-	3-12Ø (T/O)
				250	355	Bottom	3-12Ø (T/O)	-	3-12Ø (T/O)
	SECOND FLOOR	BEAM 1		250	355	Top	3-12Ø (T/O)	-	3-12Ø (T/O)
				250	355	Bottom	3-12Ø (T/O)	-	3-12Ø (T/O)
		BEAM 2		250	355	Top	3-12Ø (T/O)	-	3-12Ø (T/O)
				250	355	Bottom	3-12Ø (T/O)	-	3-12Ø (T/O)
STAIRCOVER	BEAM 1		250	355	Top	3-12Ø (T/O)	-	3-12Ø (T/O)	
			250	355	Bottom	3-12Ø (T/O)	-	3-12Ø (T/O)	
	BEAM 2		250	355	Top	3-12Ø (T/O)	-	3-12Ø (T/O)	
			250	355	Bottom	3-12Ø (T/O)	-	3-12Ø (T/O)	

BEAM 1	Beam of span upto 3m	BEAM 2	Beam of span greater than 3m and upto 4.5 m
---------------	----------------------	---------------	---

BEAM REBAR DISTRIBUTION TABLE FOR TWO STOREY BUILDING, SEISMIC ZONE FACTOR = 0.3									
SITE SUBSOIL CATEGORY C	FLOOR	Type	Beam Size		Face	Rebar Combination At Left End/ Right End(E)		Rebar Combination At Middle (M)	
			B(mm)	D(mm)		Through Bar (TH)	Extra Bars (EXT)	Through Bar (TH)	
	FIRST FLOOR	BEAM 1		250	355	Top	3-12Ø (T/O)	2-12Ø (EXT)	3-12Ø (T/O)
				250	355	Bottom	3-12Ø (T/O)	-	3-12Ø (T/O)
		BEAM 2		250	355	Top	3-12Ø (T/O)	2-12Ø (EXT)	3-12Ø (T/O)
				250	355	Bottom	3-12Ø (T/O)	-	3-12Ø (T/O)
	SECOND FLOOR	BEAM 1		250	355	Top	3-12Ø (T/O)	-	3-12Ø (T/O)
				250	355	Bottom	3-12Ø (T/O)	-	3-12Ø (T/O)
		BEAM 2		250	355	Top	3-12Ø (T/O)	-	3-12Ø (T/O)
				250	355	Bottom	3-12Ø (T/O)	-	3-12Ø (T/O)
STAIRCOVER	BEAM 1		250	355	Top	3-12Ø (T/O)	-	3-12Ø (T/O)	
			250	355	Bottom	3-12Ø (T/O)	-	3-12Ø (T/O)	
	BEAM 2		250	355	Top	3-12Ø (T/O)	-	3-12Ø (T/O)	
			250	355	Bottom	3-12Ø (T/O)	-	3-12Ø (T/O)	

BEAM 1	Beam of span upto 3m	BEAM 2	Beam of span greater than 3m and upto 4.5 m
---------------	----------------------	---------------	---

BEAM REBAR DISTRIBUTION TABLE FOR TWO STOREY BUILDING, SEISMIC ZONE FACTOR = 0.35									
SITE SUBSOIL CATEGORY C	FLOOR	Type	Beam Size		Face	Rebar Combination At Left End/ Right End(E)		Rebar Combination At Middle (M)	
			B(mm)	D(mm)		Through Bar (TH)	Extra Bars (EXT)	Through Bar (TH)	
	FIRST FLOOR	BEAM 1		250	355	Top	3-12Ø (T/O)	2-12Ø (EXT)	3-12Ø (T/O)
				250	355	Bottom	3-12Ø (T/O)	-	3-12Ø (T/O)
		BEAM 2		250	355	Top	3-12Ø (T/O)	2-12Ø (EXT)	3-12Ø (T/O)
				250	355	Bottom	3-12Ø (T/O)	-	3-12Ø (T/O)
	SECOND FLOOR	BEAM 1		250	355	Top	3-12Ø (T/O)	-	3-12Ø (T/O)
				250	355	Bottom	3-12Ø (T/O)	-	3-12Ø (T/O)
		BEAM 2		250	355	Top	3-12Ø (T/O)	-	3-12Ø (T/O)
				250	355	Bottom	3-12Ø (T/O)	-	3-12Ø (T/O)
STAIRCOVER	BEAM 1		250	355	Top	3-12Ø (T/O)	-	3-12Ø (T/O)	
			250	355	Bottom	3-12Ø (T/O)	-	3-12Ø (T/O)	
	BEAM 2		250	355	Top	3-12Ø (T/O)	-	3-12Ø (T/O)	
			250	355	Bottom	3-12Ø (T/O)	-	3-12Ø (T/O)	

BEAM 1	Beam of span upto 3m	BEAM 2	Beam of span greater than 3m and upto 4.5 m
---------------	----------------------	---------------	---

BEAM REBAR DISTRIBUTION TABLE FOR TWO STOREY BUILDING, SEISMIC ZONE FACTOR = 0.4									
SITE SUBSOIL CATEGORY C	FLOOR	Type	Beam Size		Face	Rebar Combination At Left End/ Right End(E)		Rebar Combination At	
			B(mm)	D(mm)		Through Bar (TH)	Extra Bars (EXT)	Middle (M)	
							Through Bar (TH)	Through Bar (TH)	
	FIRST FLOOR	BEAM 1		250	355	Top	3-12Ø (T/O)	2-12Ø (EXT)	3-12Ø (T/O)
				250	355	Bottom	3-12Ø (T/O)	2-12Ø (EXT)	3-12Ø (T/O)
		BEAM 2		250	355	Top	3-12Ø (T/O)	2-12Ø (EXT)	3-12Ø (T/O)
				250	355	Bottom	3-12Ø (T/O)	-	3-12Ø (T/O)
	SECOND FLOOR	BEAM 1		250	355	Top	3-12Ø (T/O)	-	3-12Ø (T/O)
				250	355	Bottom	3-12Ø (T/O)	-	3-12Ø (T/O)
		BEAM 2		250	355	Top	3-12Ø (T/O)	-	3-12Ø (T/O)
			250	355	Bottom	4-12Ø (T/O)	-	4-12Ø (T/O)	
STAIRCOVER	BEAM 1		250	355	Top	3-12Ø (T/O)	-	3-12Ø (T/O)	
			250	355	Bottom	3-12Ø (T/O)	-	3-12Ø (T/O)	
	BEAM 2		250	355	Top	3-12Ø (T/O)	-	3-12Ø (T/O)	
			250	355	Bottom	3-12Ø (T/O)	-	3-12Ø (T/O)	

BEAM 1	Beam of span upto 3m	BEAM 2	Beam of span greater than 3m and upto 4.5 m
---------------	----------------------	---------------	---

**TABLE 8-11 BEAM REINFORCEMENT DISTRIBUTION OF TWO STOREY BUILDING FOR
0.35 SEISMIC ZONE AND SITE SUB SOIL CATEGORY D**

BEAM REBAR DISTRIBUTION TABLE FOR TWO STOREY BUILDING, SEISMIC ZONE FACTOR = 0.35									
SITE SUBSOIL CATEGORY D	FLOOR	Type	Beam Size		Face	Rebar Combination At Left End/ Right End (E)		Rebar Combination At Middle (M)	
			B(mm)	D(mm)		Through Bar (TH)	Extra Bars (EXT)	Through Bar (TH)	
	FIRST FLOOR	BEAM 1		250	355	Top	3-12Ø (T/O)	2-12Ø (EXT)	3-12Ø (T/O)
				250	355	Bottom	3-12Ø (T/O)	-	3-12Ø (T/O)
		BEAM 2		250	355	Top	3-12Ø (T/O)	2-12Ø (EXT)	3-12Ø (T/O)
				250	355	Bottom	3-12Ø (T/O)	-	3-12Ø (T/O)
	SECOND FLOOR	BEAM 1		250	355	Top	3-12Ø (T/O)	-	3-12Ø (T/O)
				250	355	Bottom	3-12Ø (T/O)	-	3-12Ø (T/O)
		BEAM 2		250	355	Top	3-12Ø (T/O)	-	3-12Ø (T/O)
				250	355	Bottom	3-12Ø (T/O)	-	3-12Ø (T/O)
STAIRCOVER	BEAM 1		250	355	Top	3-12Ø (T/O)	-	3-12Ø (T/O)	
			250	355	Bottom	3-12Ø (T/O)	-	3-12Ø (T/O)	
	BEAM 2		250	355	Top	3-12Ø (T/O)	-	3-12Ø (T/O)	
			250	355	Bottom	3-12Ø (T/O)	-	3-12Ø (T/O)	

BEAM 1	Beam of span upto 3m	BEAM 2	Beam of span greater than 3m and upto 4.5 m
---------------	----------------------	---------------	---

[Notes:

- i. *Fe 500 (TMT) grade steel shall be used for all longitudinal reinforcements and stirrups/closed tie in beams and concrete grade shall be M20 for all beams.*
- ii. *Clear cover to stirrups in beams shall be 25mm.*
- iii. *In beam detail, **M** represents **Middle Beam Section**, **E** represents **Left End/ Right End**; **TH** represents **Throughout Bars** and **EXT** represents **Extra Bars**.*
- iv. *Beam sizes and reinforcement details for pre-determined seismic zone and site subsoil category according to two storey building shall be adopted from **Table 8-10** & **Table 8-11**. In a continuous junction of a beam, extra bars from beam section (left/right) shall be continued to adjacent beam section.*
- v. *Rebar distribution in beam shall be followed from **Figure 8-5** and as per sizes mentioned **Table 8-10** & **Table 8-11**.*
- vi. *Top and bottom extra bars shall be curtailed 0.3L away from support but for span less than minimum span of 2.1 m, extra bars shall not be curtailed.*
- vii. *Lapping of top and bottom bar is allowed only in the zone shown in typical floor beam drawing in **Figure 8-4** and not more than 50% of the bars should be spliced at a section.*
- viii. *Anchorage of longitudinal reinforcement of beam shall be followed as in **Figure 8-6**.*
- ix. *Transverse reinforcement in beam shall be adopted **Figure 8-4** in conjunction with **Table 9-13**.*
- x. *In normal circumstances formwork of slab and beam can be removed after 3 weeks of concreting.*
- xi. *Lapping of bars shall not be less than 57ϕ or as in **Table 9-10**.*
- xii. *All stirrups are of closed type and 135° hook should be used with minimum hook length of 65mm.]*

9. Three Storey Building

9.1 Foundation

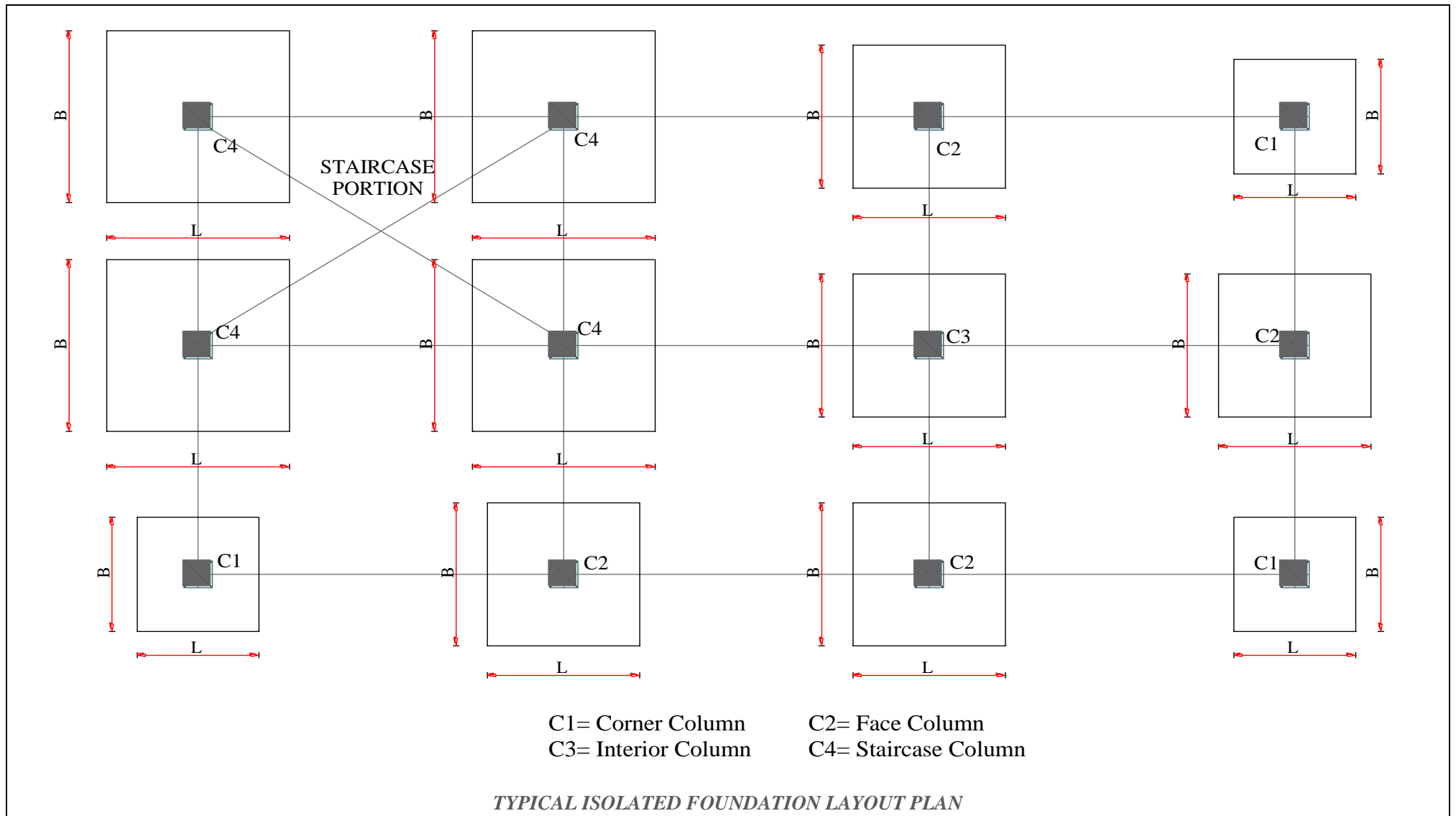
This section covers isolated footing and one-way eccentric isolated footing for three storey building and predetermined soil bearing capacity as presented in **Cl 3.3 to Cl 3.5**. Such footing shall rest on firm and well compacted ground and shall not be constructed in areas as covered in **Cl 3.1**.

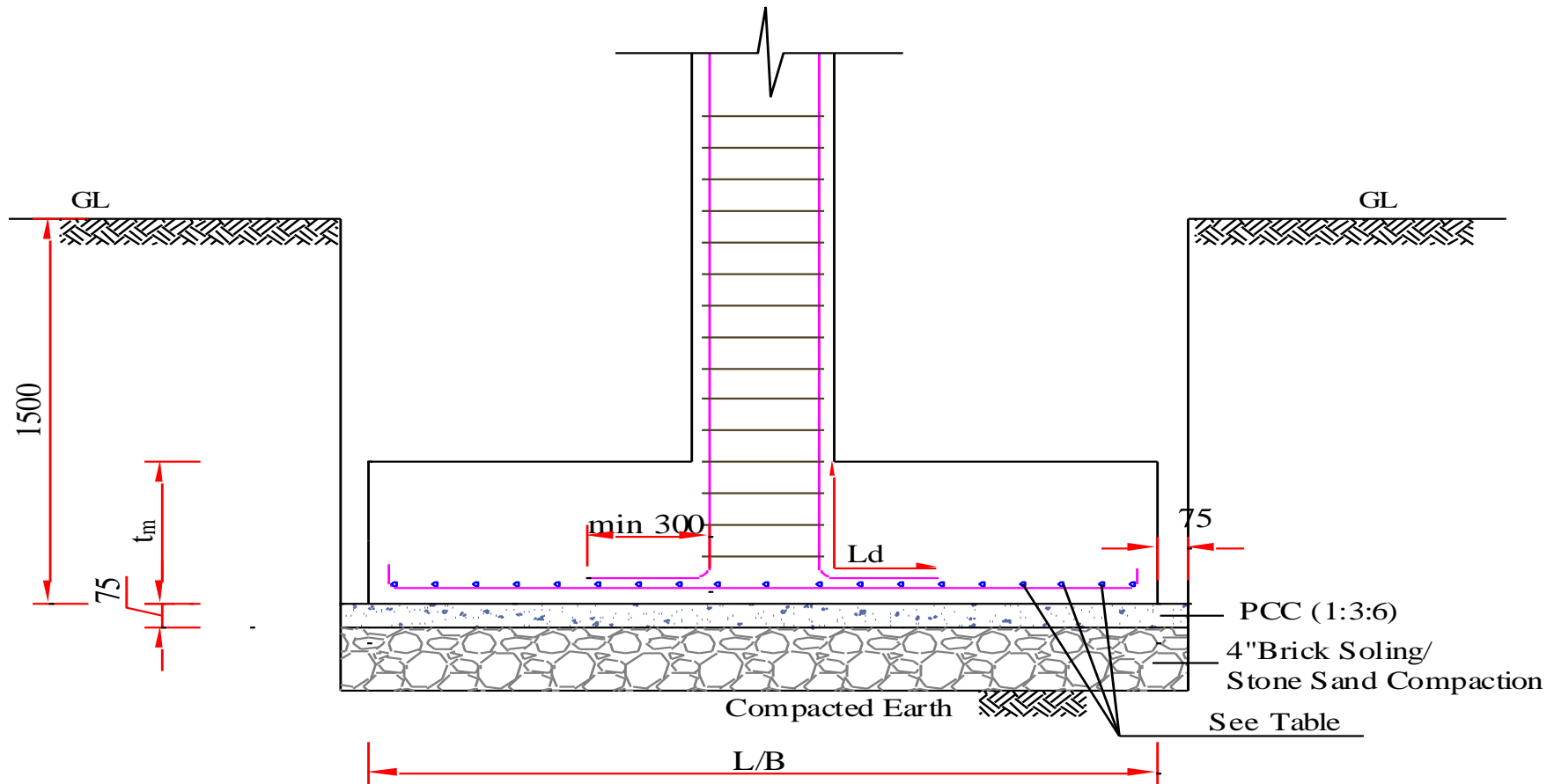
Combined Footing: When two or more adjacent footings overlap to form a combined footing, the footing shall be designed using professional engineering practice which is not covered by this RUD.

9.1.1 Isolated Footing

Isolated Footing: The sizes of isolated footing and corresponding reinforcement for two storey building with different soil bearing capacity(SBC) shall be adopted from **Table 9-1 to Table 9-3**. Details of isolated footing for three storey shall be as given in **Figure 9-1**. All plinth beams shall be constructed on a toe wall as shown in **Figure 9-1** and **Figure 9-2**.

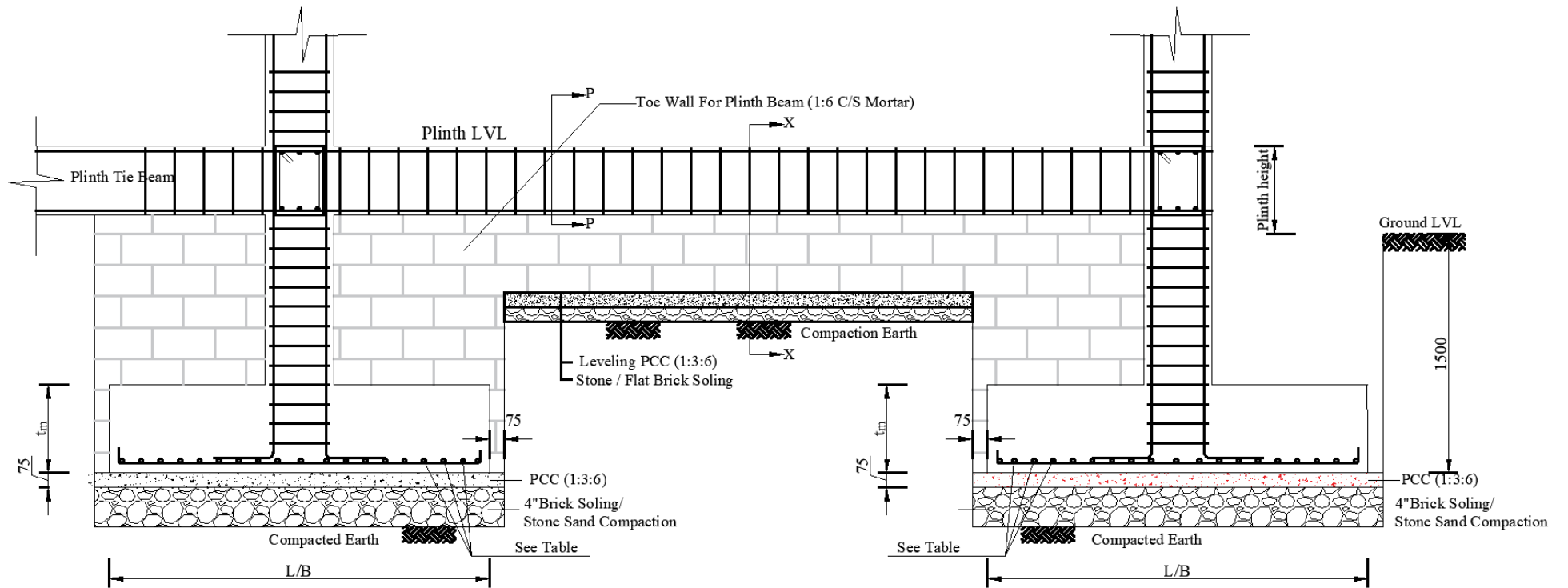
FIGURE 9-1 TYPICAL ISOLATED FOOTING DETAIL OF THREE STOREY BUILDING





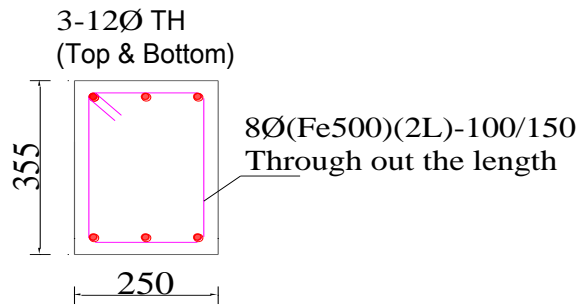
TYPICAL ISOLATED FOOTING SECTION
COVER FOR SIDE FACE = 75 MM; COVER FOR BOTTOM FACE = 50 MM

Note: Soiling with Brick (Brick Soiling) shall be not less than 4" and Soiling with Stone (Stone Soiling) shall be not less than 6"

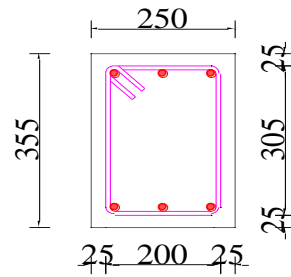


TYPICAL ISOLATED FOOTING, TOE WALL AND PLINTH TIE BEAM SECTION

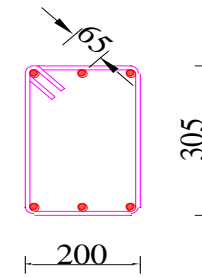
Note: Soiling with Brick (Brick Soiling) shall be not less than 4" and Soiling with Stone (Stone Soiling) shall be not less than 6"



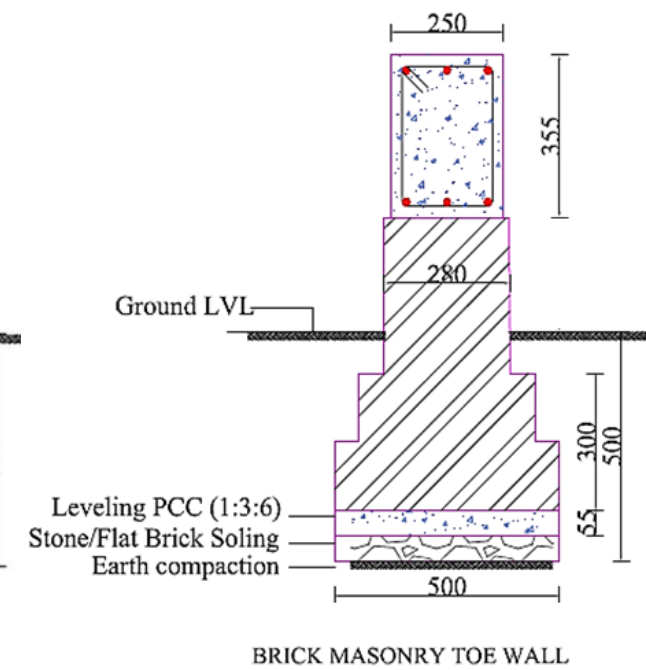
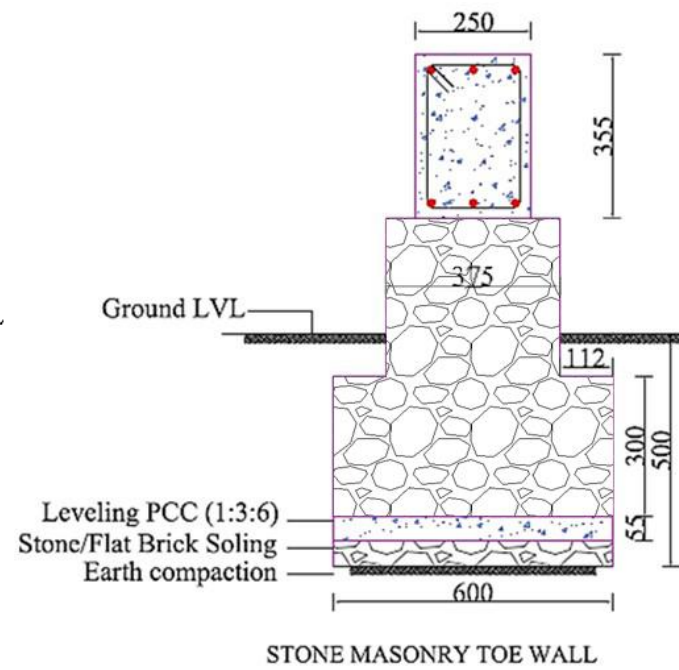
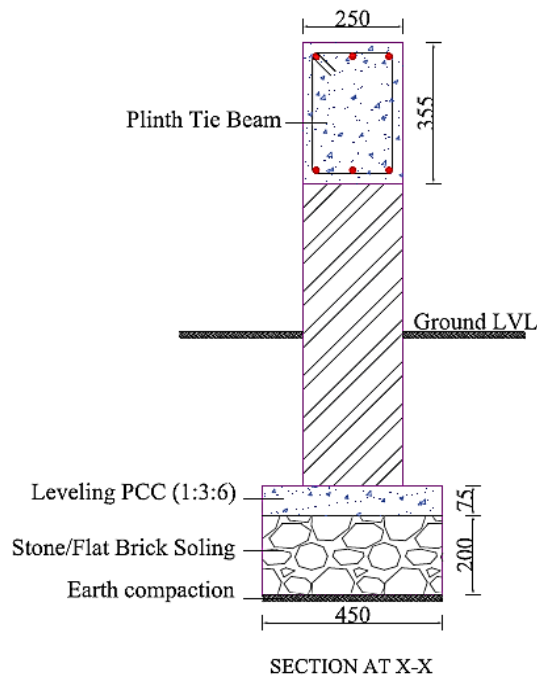
Plinth Tie Beam Section P-P



Typical Beam Section P-P



Size of Stirrups of dia 8mm



**TABLE 9-1 ISOLATED FOOTING SIZE FOR THREE STOREY BUILDING
(SOIL BEARING CAPACITY= 200 KN/M²)**

Column Type	Foundation Plan, L=B (m)	Foundation Thickness, tm (mm)	Reinforcement Each Way
Corner	1.5	400	12Ø @150 mm c-c spacing
Face	1.6	400	12Ø @100 mm c-c spacing
Interior	1.6	400	12Ø @100 mm c-c spacing
Staircase	1.9	400	16Ø @100 mm c-c spacing

**TABLE 9-2 ISOLATED FOOTING SIZE FOR THREE STOREY BUILDING
(SOIL BEARING CAPACITY= 150 KN/M²)**

Column Type	Foundation Plan, L=B (m)	Foundation Thickness, tm (mm)	Reinforcement Each Way
Corner	1.5	400	12Ø @150 mm c-c spacing
Face	1.9	400	12Ø @100 mm c-c spacing
Interior	1.9	400	12Ø @100 mm c-c spacing
Staircase	2.25	400	16Ø @100 mm c-c spacing

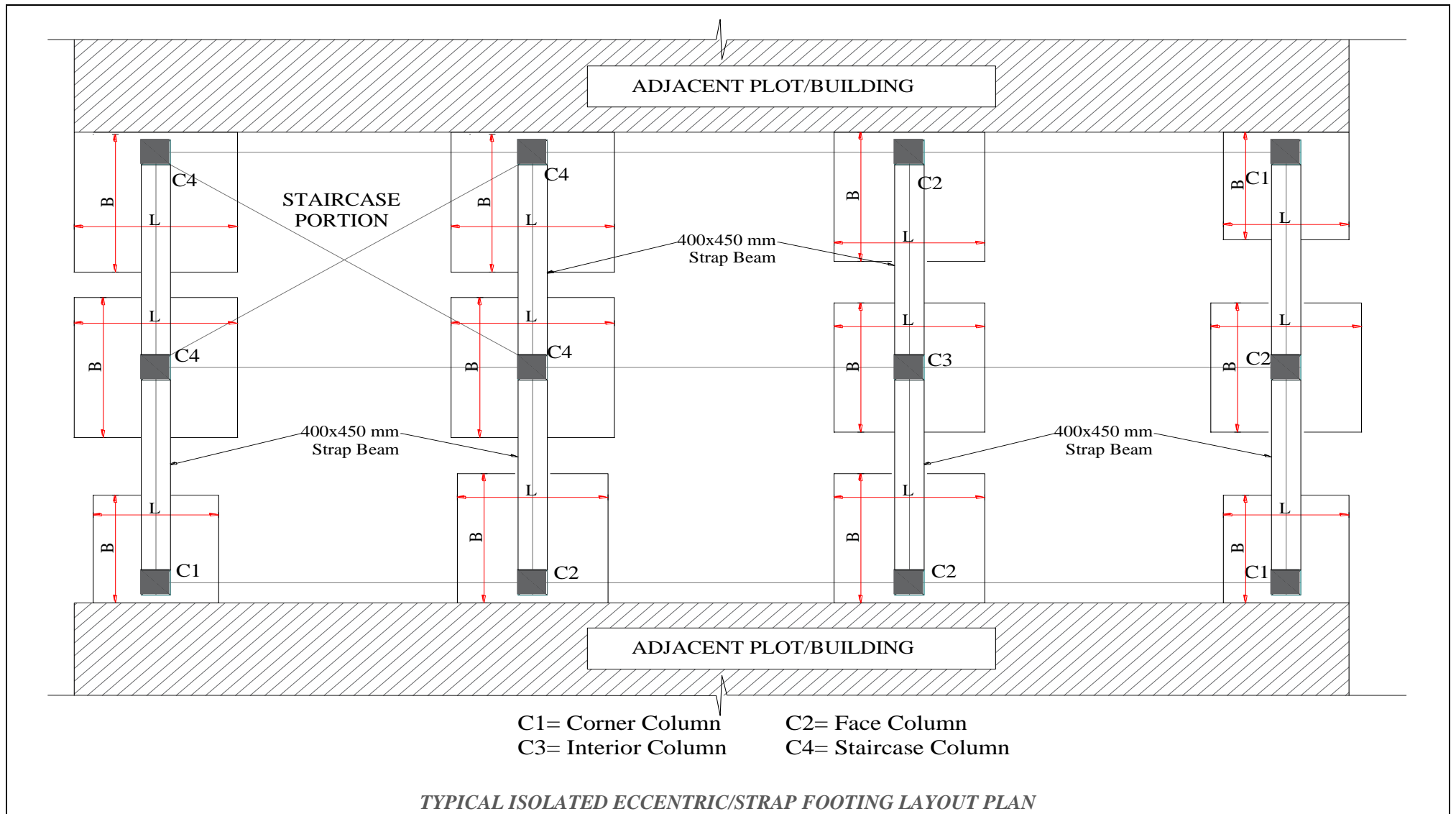
**TABLE 9-3 ISOLATED FOOTING SIZE FOR THREE STOREY BUILDING
(SOIL BEARING CAPACITY= 100 KN/M²)**

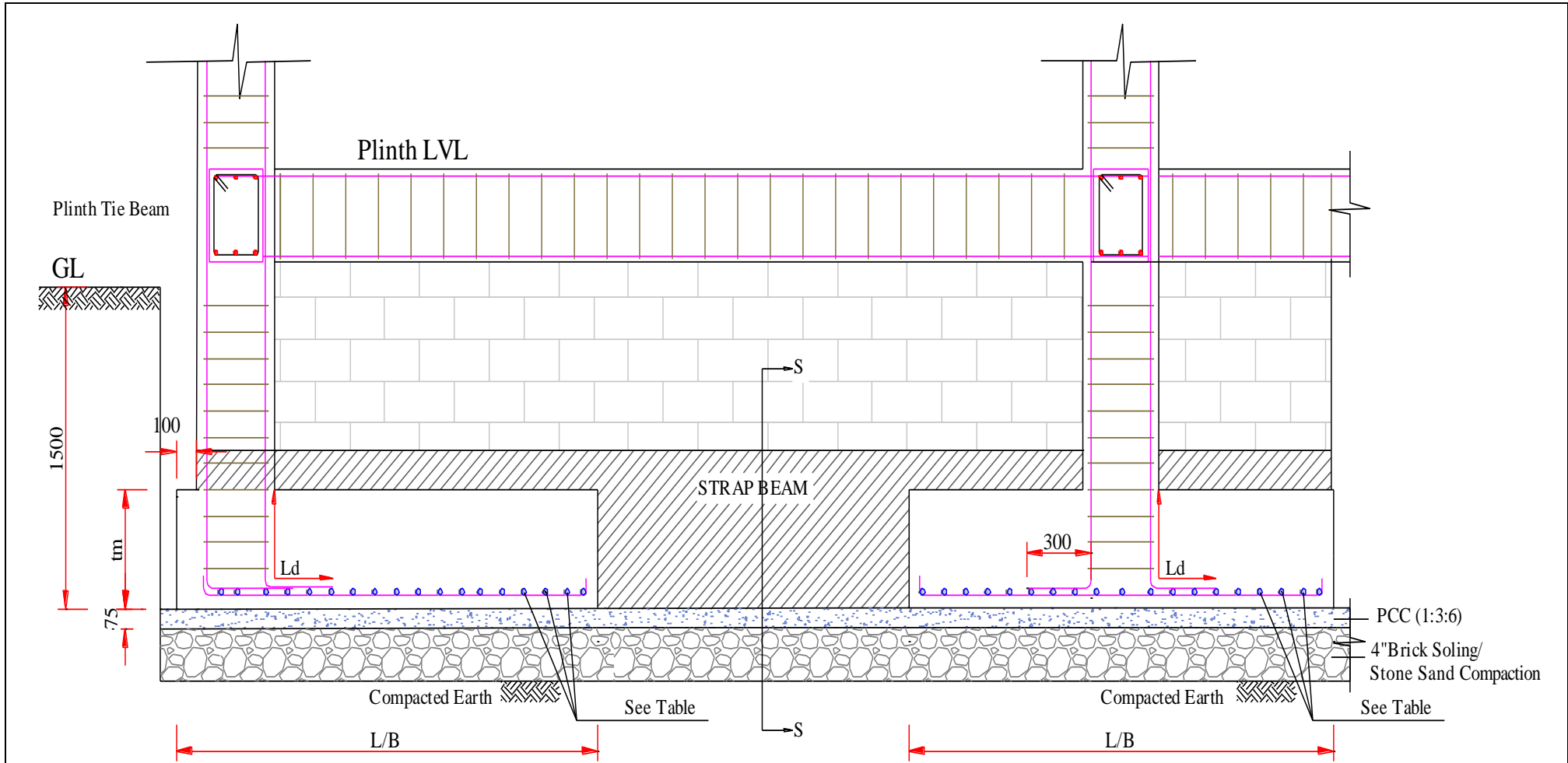
Column Type	Foundation Plan, L=B (m)	Foundation Thickness, tm (mm)	Reinforcement Each Way
Corner	1.75	400	12Ø @150 mm c-c spacing
Face	2.4	400	16Ø @100 mm c-c spacing
Interior	2.4	400	16Ø @100 mm c-c spacing
Staircase	2.8	400	16Ø @100 mm c-c spacing

9.2.1 Eccentric Isolated Footing

Eccentric Isolated Footing/Strap Footing: Footing shall be eccentric in one direction only as shown in **Figure 9-2** if it is required at site. Such eccentric footing/strap footing for three storey building shall be accompanied by strap beam as shown in **Figure 9-2**. Similarly, for such eccentric footing, sizes and reinforcement arrangement shall be adopted from **Table 9-4** to **Table 9-5**. All plinth beams shall be constructed on a toe wall as shown in **Figure 9-1** and **Figure 9-2**.

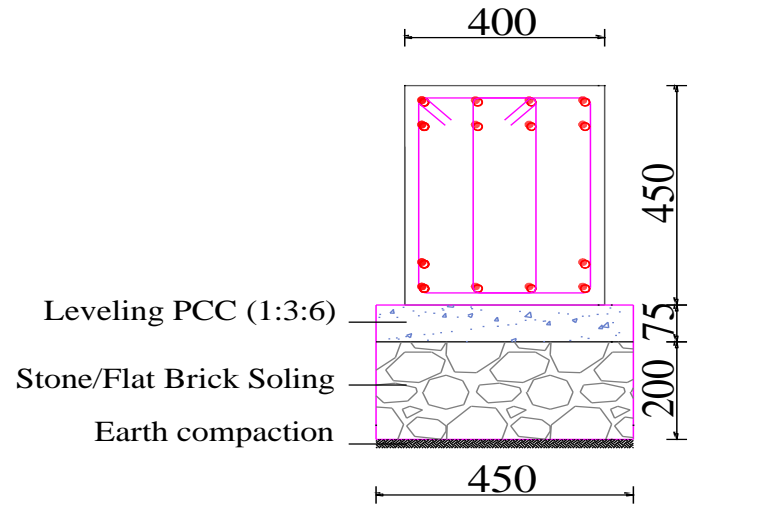
FIGURE 9-2 TYPICAL ECCENTRIC FOOTING DETAIL OF THREE STOREY BUILDING



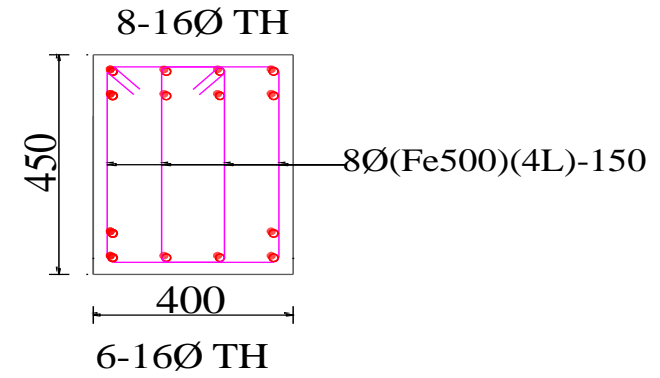


TYPICAL ISOLATED ECCENTRIC/STRAP FOOTING SECTION

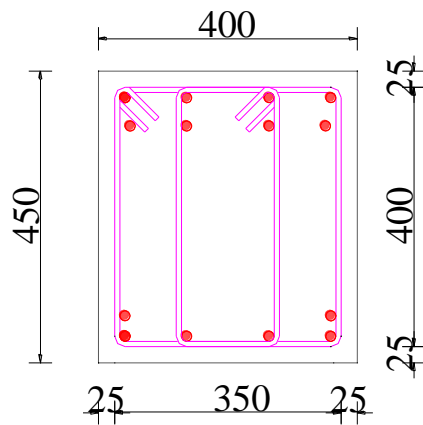
Note: Soiling with Brick (Brick Soiling) shall be not less than 4" and Soiling with Stone (Stone Soiling) shall be not less than 6"



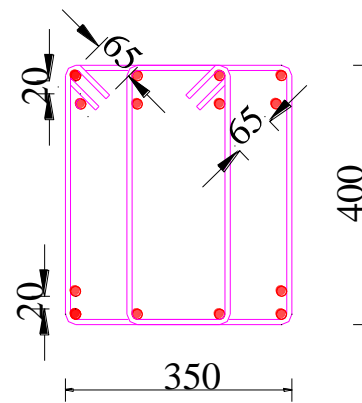
STRAP BEAM (SECTION S-S)



REBAR DETAIL IN STRAP BEAM

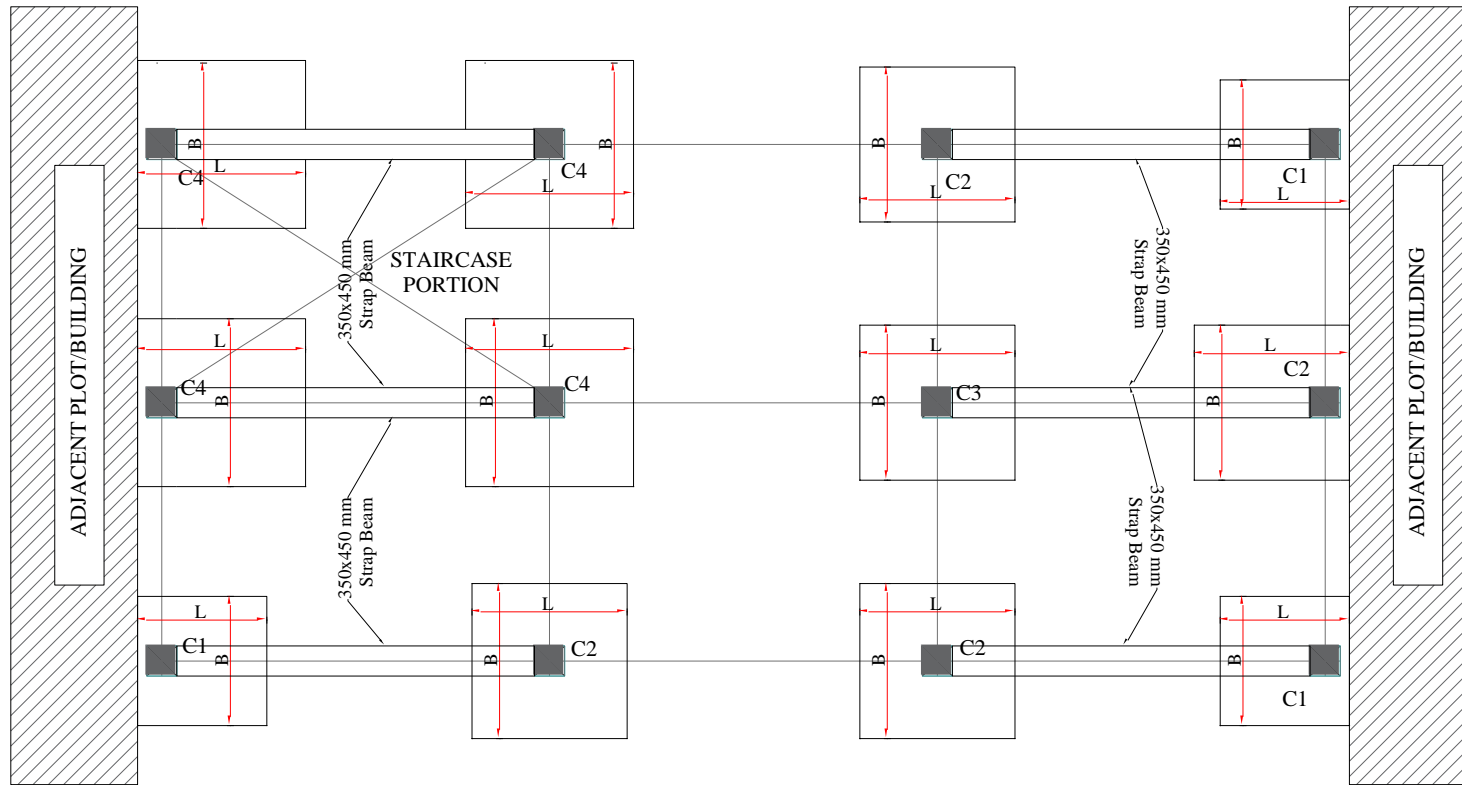


TYPICAL STRAP BEAM SECTION



SIZE OF STIRRUPS OF DIA 8MM

FIGURE 8-3 (B) TYPICAL ECCENTRIC FOOTING DETAIL



C1= Corner Column C2= Face Column
 C3= Interior Column C4= Staircase Column

TYPICAL ISOLATED ECCENTRIC/STRAP FOOTING LAYOUT PLAN

**TABLE 9-4 ECCENTRIC ISOLATED FOOTING SIZE FOR THREE STOREY BUILDING
(BEARING CAPACITY= 200 KN/M²)**

Column Type	Foundation Plan, L=B (m)	Foundation Thickness, tm (mm)	Reinforcement Each Way
Corner	1.5	400	12Ø @150 mm c-c spacing
Face	1.6	400	12Ø @100 mm c-c spacing
Interior	1.6	400	12Ø @100 mm c-c spacing
Staircase	2	400	16Ø @150 mm c-c spacing

**TABLE 9-5 ECCENTRIC ISOLATED FOOTING SIZE FOR THREE STOREY BUILDING
(BEARING CAPACITY= 150 KN/M²)**

Column Type	Foundation Plan, L=B (m)	Foundation Thickness, tm (mm)	Reinforcement Each Way
Corner	1.75	400	12Ø @150 mm c-c spacing
Face	2.1	400	12Ø @100 mm c-c spacing
Interior	1.9	400	12Ø @100 mm c-c spacing
Staircase	2.4	400	16Ø @150 mm c-c spacing

**TABLE 9-6 ECCENTRIC ISOLATED FOOTING SIZE FOR THREE STOREY BUILDING
(BEARING CAPACITY= 125 KN/M²)**

Column Type	Foundation Plan, L=B (m)	Foundation Thickness, tm (mm)	Reinforcement Each Way
Corner	2.1	400	12Ø @150 mm c-c spacing
Face	2.4	400	12Ø @100 mm c-c spacing
Interior	2.4	400	12Ø @100 mm c-c spacing
Staircase	2.9	400	16Ø @100 mm c-c spacing

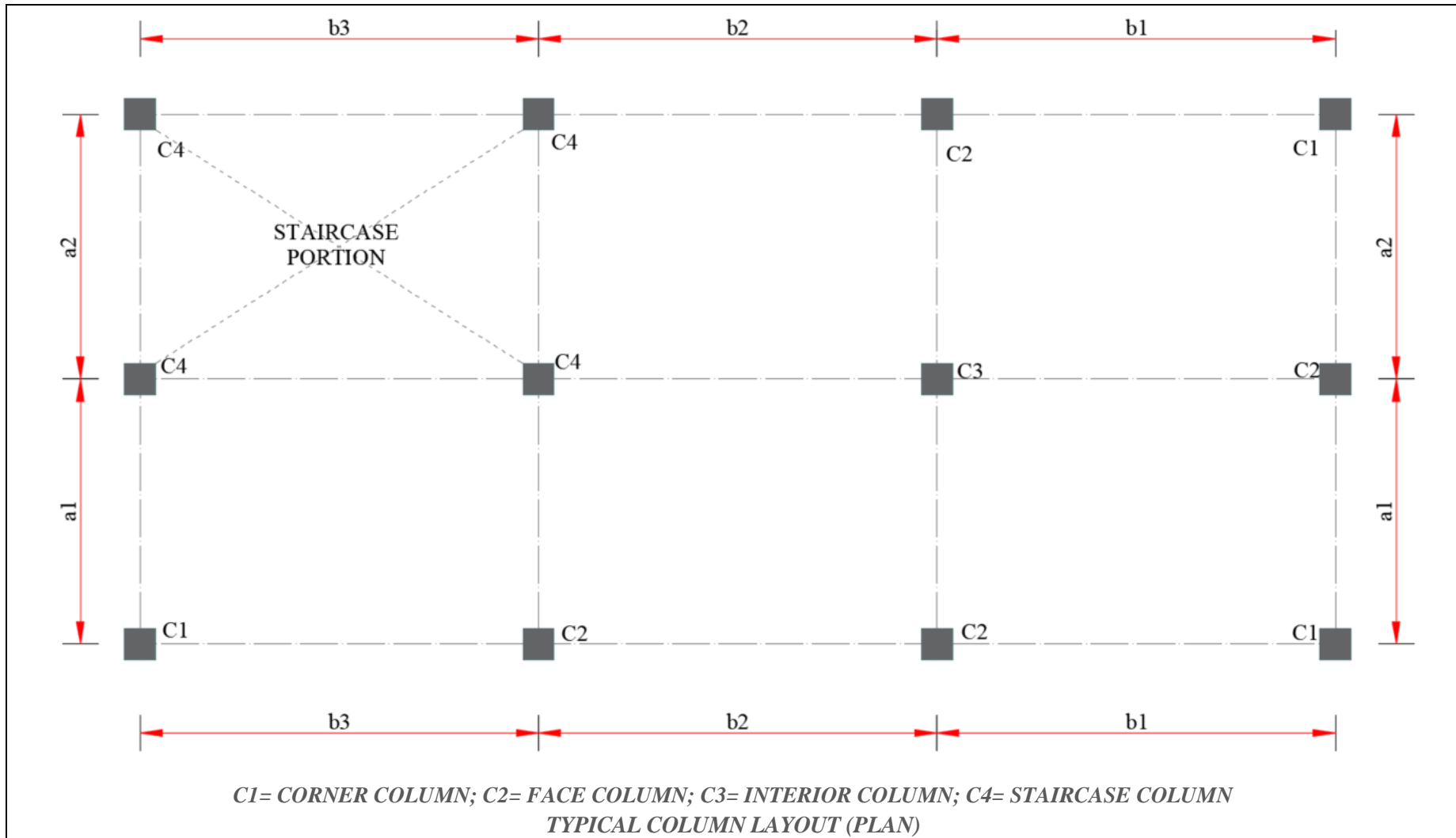
[Note:

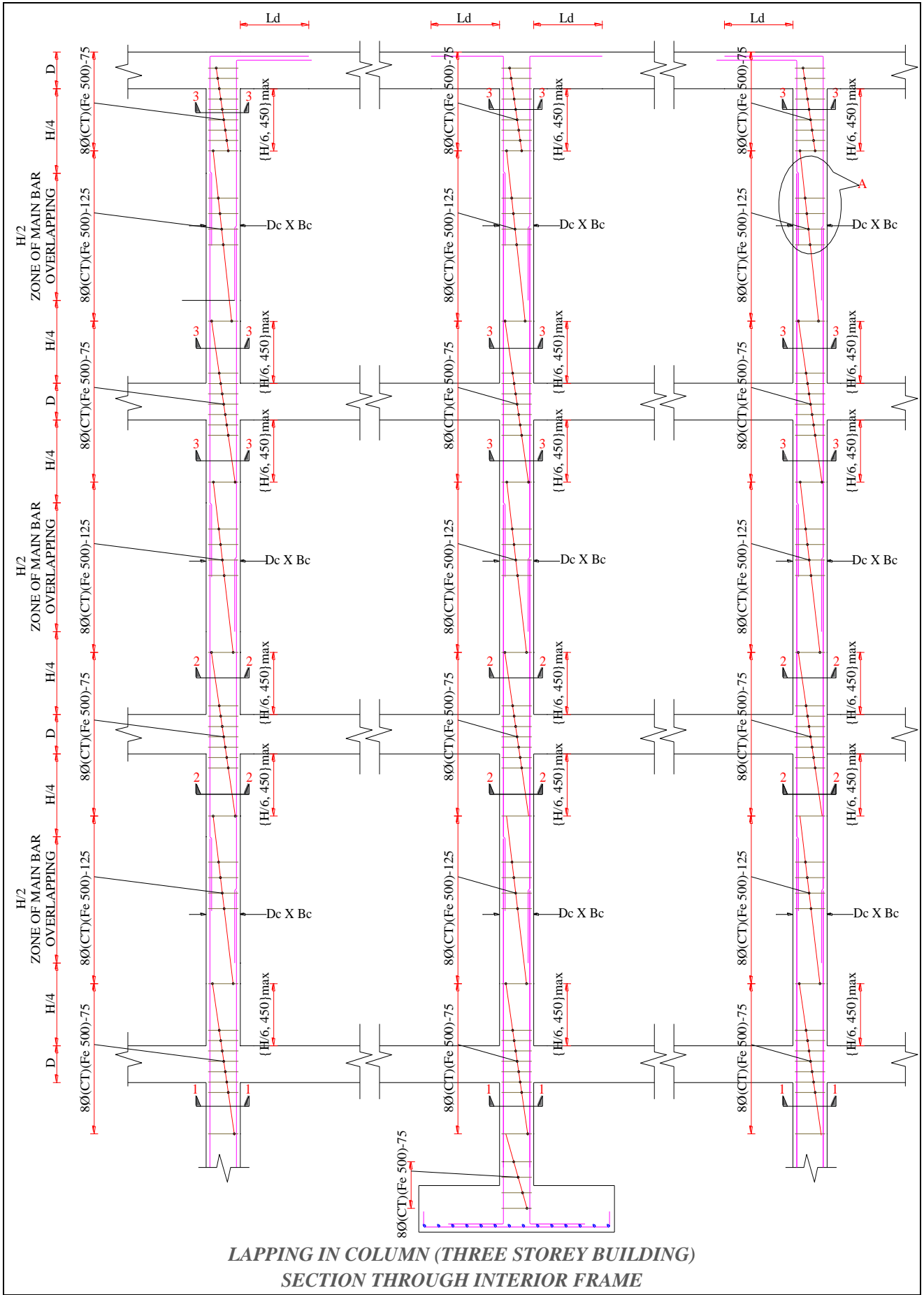
1. Fe 500 (TMT) grade steel shall be used for all longitudinal reinforcements and stirrups/closed tie in beams and concrete grade shall be M20 for all footings and strap beams
2. Gravel packing is recommended to improve the soil bearing capacity of weak soil, however the footing size shall be adopted from **Table 8-1 to Table 9-6**.
3. Eccentric footing shall be accompanied by strap beam whose size and reinforcement shall be adopted from **Figure 9-2**.
4. When more than two footing merge to form combine footing, the detail shall not be followed from this RUD and shall be designed using professional engineering practice
5. Footing with dimension and SBC less than provided in **Table 9-1 to Table 9-5**. due to site condition shall be designed using professional engineering practice.]

9.2 Column

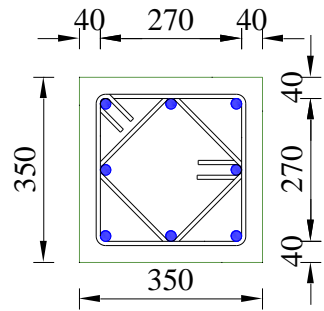
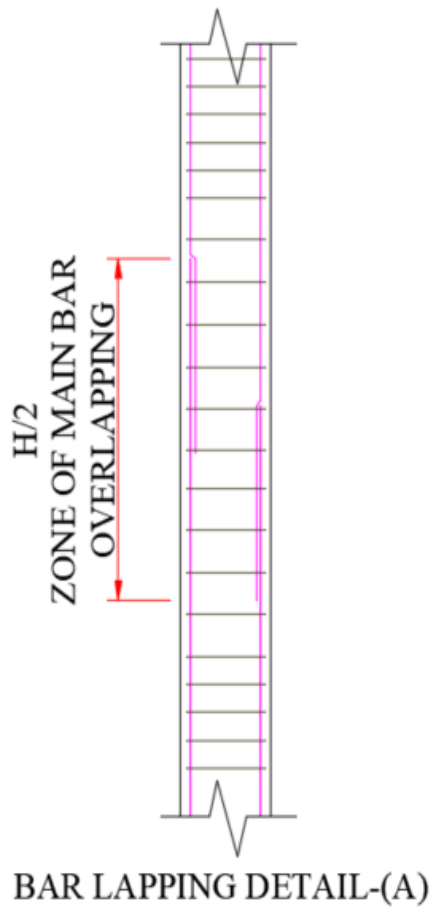
This section covers size and reinforcement detail of column for three storey building with predetermined seismic zoning factor and site sub soil condition.

FIGURE 9-4 TYPICAL COLUMN DETAIL FOR THREE STOREY BUILDING

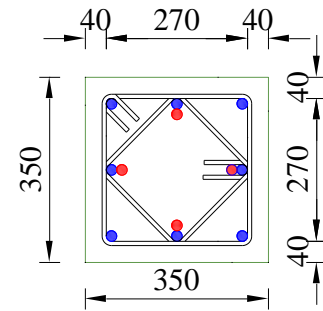
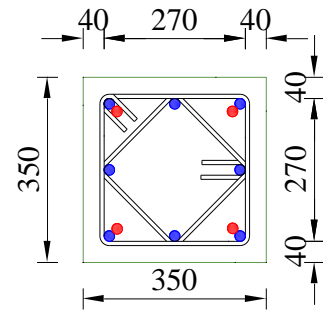




**LAPPING IN COLUMN (THREE STOREY BUILDING)
SECTION THROUGH INTERIOR FRAME**

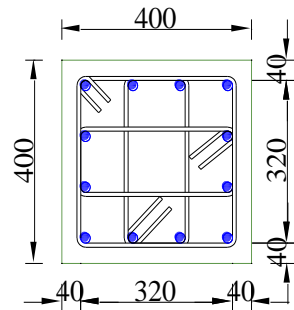


Typical Column (350x350mm) Section

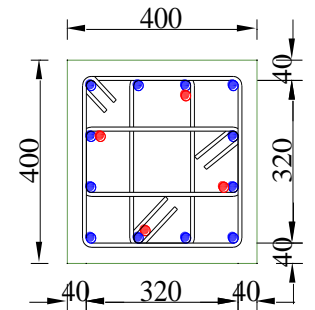
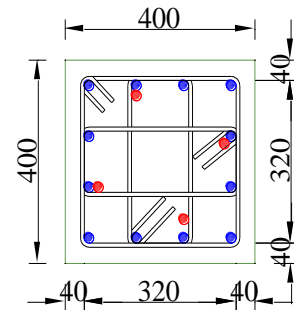
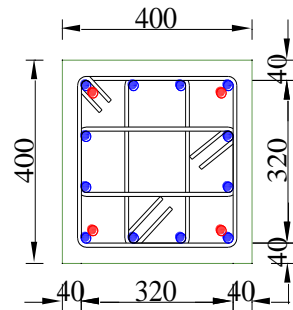


● - Curtailed Bar ● - Spliced Bar

Typical Column (350x350mm) Section At
Splicing/Lapping Zone

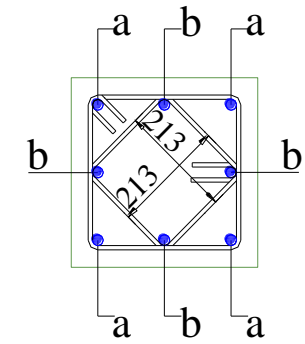


Typical Column (400x400mm) Section

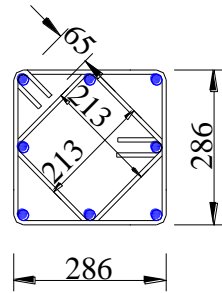


● - Curtailed Bar ● - Spliced Bar

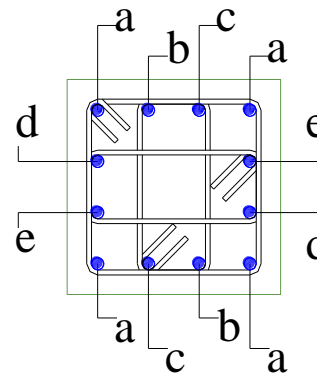
Typical Column (400x400mm) Section At
Splicing/Lapping Zone



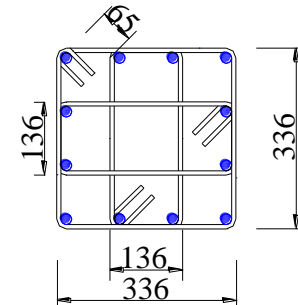
Rebar Configuration in 350x350mm Column Size



Size of Stirrups of dia 8mm For 350x350mm Column Size



Rebar Configuration in 400x400mm Column Size



Size of Stirrups of dia 8mm For 400x400mm Column Size

8Ø(CT)(Fe 500)-125

↑ c/c spacing
 ↑ Grade of Steel
 ↑ Closed Tie
 ↑ Diameter of Bar

4-16Ø (Fe 500)

↑ Grade of Steel
 ↑ Diameter of Bar
 ↑ No. of Bars

**TABLE 8. 1 REINFORCEMENT ARRANGEMENT OF COLUMN (350MM X350MM & 400MM X 400MM)
FOR DIFFERENT REBAR COMBINATION OF THREE STOREY BUILDING**

ARRANGEMENT OF 8 NUMBERS OF REBAR IN COLUMN							
S.NO.	COLUMN REBAR CONFIGURATION	REBAR COMBINATION	BAR SIZE 'a' (mm)	BAR SIZE 'b' (mm)			
1		8-20Ø	20Ø	20Ø			
2		4-20Ø+4-16Ø	20Ø	16Ø			
3		8-16Ø	16Ø	16Ø			
4		4-16Ø+4-12Ø	16Ø	12Ø			
ARRANGEMENT OF 12 NUMBERS OF REBAR IN COLUMN							
S.NO.	COLUMN REBAR CONFIGURATION	REBAR COMBINATION	BAR SIZE 'a' (mm)	BAR SIZE 'b' (mm)	BAR SIZE 'c' (mm)	BAR SIZE 'd' (mm)	BAR SIZE 'e' (mm)
1		8-20Ø+4-16Ø	20Ø	20Ø	16Ø	20Ø	16Ø
2		4-20Ø+8-16Ø	20Ø	16Ø	16Ø	16Ø	16Ø
3		12-16Ø	16Ø	16Ø	16Ø	16Ø	16Ø
4		8-16Ø+4-12Ø	16Ø	16Ø	12Ø	16Ø	12Ø
5		4-16Ø+8-12Ø	16Ø	12Ø	12Ø	12Ø	12Ø

TABLE 9-7 COLUMN REINFORCEMENT DETAILS OF THREE STOREY BUILDING FOR DIFFERENT SEISMIC ZONES FOR SITE SUB SOIL CATEGORY C

COLUMN REINFORCEMENT DETAIL FOR THREE STOREY BUILDING; SEISMIC ZONE FACTOR= 0.25 CONCRETE GRADE= M20; STEEL GRADE=Fe 500 (TMT)						
SITE TYPE C	COLUMN LOCATION	CORNER (C1)	FACE (C2)	INTERIOR (C3)	STAIRCASE (C4)	STIRRUPS (ALL FLOOR)
	GROUND FLOOR	 350 350 4-20Ø+4-16Ø	 350 350 8-16Ø	 350 350 4-16Ø+4-12Ø	 350 350 4-20Ø+4-16Ø	 8Ø@ 75 /125 mm c/c
	FIRST FLOOR	 350 350 4-16Ø+4-12Ø	 350 350 4-16Ø+4-12Ø	 350 350 4-16Ø+4-12Ø	 350 350 8-16Ø	
	SECOND FLOOR	 350 350 4-16Ø+4-12Ø	 350 350 4-16Ø+4-12Ø	 350 350 4-16Ø+4-12Ø	 350 350 4-16Ø+4-12Ø	
	STAIRCOVER	—	—	—	 350 350 4-16Ø+4-12Ø	
COLUMN REINFORCEMENT DETAIL FOR THREE STOREY BUILDING; SEISMIC ZONE FACTOR= 0.3 CONCRETE GRADE= M20; STEEL GRADE=Fe 500 (TMT)						
SITE TYPE C	COLUMN LOCATION	CORNER (C1)	FACE (C2)	INTERIOR (C3)	STAIRCASE (C4)	STIRRUPS (ALL FLOOR)
	GROUND FLOOR	 350 350 4-20Ø+4-16Ø	 350 350 4-20Ø+4-16Ø	 350 350 8-16Ø	 350 350 8-20Ø	 8Ø@ 75 /125 mm c/c
	FIRST FLOOR	 350 350 8-16Ø	 350 350 8-16Ø	 350 350 4-16Ø+4-12Ø	 350 350 4-20Ø+4-16Ø	
	SECOND FLOOR	 350 350 4-16Ø+4-12Ø	 350 350 4-16Ø+4-12Ø	 350 350 4-16Ø+4-12Ø	 350 350 8-16Ø	
	STAIRCOVER	—	—	—	 350 350 4-16Ø+4-12Ø	

**COLUMN REINFORCEMENT DETAIL FOR THREE STOREY BUILDING;
SEISMIC ZONE FACTOR= 0.35
CONCRETE GRADE= M20; STEEL GRADE=Fe 500 (TMT)**

SITE TYPE C	COLUMN LOCATION	CORNER (C1)	FACE (C2)	INTERIOR (C3)	STAIRCASE (C4)	STIRRUPS (ALL FLOOR)
	GROUND FLOOR	 350 350 8-20Ø	 350 350 4-20Ø+4-16Ø	 350 350 4-20Ø+4-16Ø	 400 400 4-20Ø+8-16Ø	
	FIRST FLOOR	 350 350 4-20Ø+4-16Ø	 350 350 8-16Ø	 350 350 8-16Ø	 400 400 12-16Ø	
	SECOND FLOOR	 350 350 8-16Ø	 350 350 4-16Ø+4-12Ø	 350 350 4-16Ø+4-12Ø	 400 400 8-16Ø+4-12Ø	
	STAIRCOVER	—	—	—	 400 400 4-16Ø+8-12Ø	

**COLUMN REINFORCEMENT DETAIL FOR THREE STOREY BUILDING;
SEISMIC ZONE FACTOR= 0.4
CONCRETE GRADE= M20; STEEL GRADE=Fe 500 (TMT)**

SITE TYPE C	COLUMN LOCATION	CORNER (C1)	FACE (C2)	INTERIOR (C3)	STAIRCASE (C4)	STIRRUPS (ALL FLOOR)
	GROUND FLOOR	 350 350 8-20Ø	 350 350 4-20Ø+4-16Ø	 350 350 4-20Ø+4-16Ø	 400 400 4-20Ø+8-16Ø	
	FIRST FLOOR	 350 350 4-20Ø+4-16Ø	 350 350 4-20Ø+4-16Ø	 350 350 4-20Ø+4-16Ø	 400 400 12-16Ø	
	SECOND FLOOR	 350 350 8-16Ø	 350 350 8-16Ø	 350 350 8-16Ø	 400 400 8-16Ø+4-12Ø	
	STAIRCOVER	—	—	—	 400 400 4-16Ø+8-12Ø	

**TABLE 9-8 COLUMN REINFORCEMENT DETAILS OF THREE STOREY BUILDING FOR
0.35 SEISMIC ZONE FOR SITE SUB SOIL CATEGORY D**

COLUMN REINFORCEMENT DETAIL FOR THREE STOREY BUILDING; SEISMIC ZONE FACTOR= 0.35 CONCRETE GRADE= M20; STEEL GRADE=Fe 500 (TMT)						
SITE TYPE D	COLUMN LOCATION	CORNER (C1)	FACE (C2)	INTERIOR (C3)	STAIRCASE (C4)	STIRRUPS (ALL FLOOR)
	GROUND FLOOR	350 350 8-20Ø	350 350 4-20Ø+4-16Ø	350 350 4-20Ø+4-16Ø	350 350 8-20Ø	 8Ø@ 75 /125 mm c/c
	FIRST FLOOR	350 350 4-20Ø+4-16Ø	350 350 8-16Ø	350 350 8-16Ø	350 350 4-20Ø+4-16Ø	
	SECOND FLOOR	350 350 8-16Ø	350 350 4-16Ø+4-12Ø	350 350 4-16Ø+4-12Ø	350 350 8-16Ø	
	STAIRCOVER	—	—	—	350 350 4-16Ø+4-12Ø	

[Note:

- i. Fe 500 (TMT) grade steel shall be used for all longitudinal reinforcements and stirrups/closed tie and concrete grade shall be M20 for all columns.
- ii. Clear cover to stirrups should be 40mm.
- iii. Column sizes and respective reinforcement details for pre-determined seismic zone and site subsoil category according to three storey building shall be adopted from **Table 9-7 & Table 9-8**.
- iv. Reinforcement arrangement and stirrups sizes in column for two storey building for respective column sizes shall be adopted **Figure 9-3**.
- v. Splicing of longitudinal bar shall be allowed only in the zone shown in **Figure 9-3** and not more than 50% of the bars should be spliced at a section.
- vi. Lapping of bars should not be less than 57ϕ or as in **Table 9-10**.
- vii. Transverse stirrups in columns shall be adopted from **Table 9-9**.

8.2.2 Transverse Stirrups:

TABLE 9-9 TRANSVERSE STIRRUPS FOR COLUMN

Zone	Special Confinement Zone and Splicing Zone	Remaining Column Height
Floor Level	Fe 500	Fe 500
Stair cover	8mm Ø @ 75 mm c/c	8mm Ø @ 125 mm c/c
Second Floor	8mm Ø @ 75 mm c/c	8mm Ø @ 125 mm c/c
First Floor	8mm Ø @ 75 mm c/c	8mm Ø @ 125 mm c/c
Upto Ground Floor	8mm Ø @ 75 mm c/c	8mm Ø @ 125 mm c/c

[Note:

1. Continue the column stirrups as specified as special confining reinforcements, if column stands adjacent to a window or such opening to take care of the short-column effect.
2. All stirrups are of closed type.
3. 135° Hook should be used with minimum hook length of 65mm.]

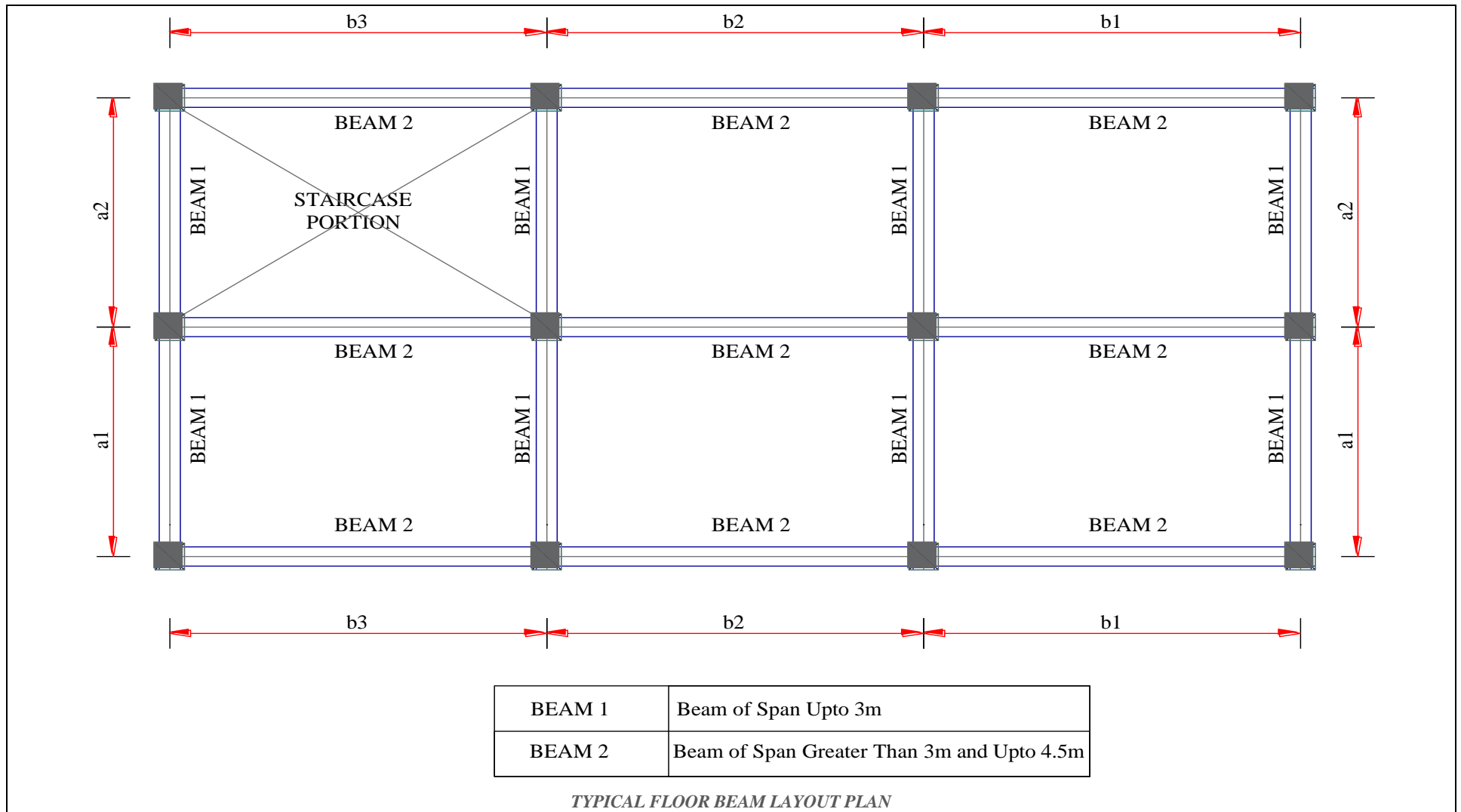
TABLE 9-10 DEVELOPMENT LENGTH OF REBAR FOR M20 GRADE CONCRETE & FE 500 (TMT)
REINFORCEMENT

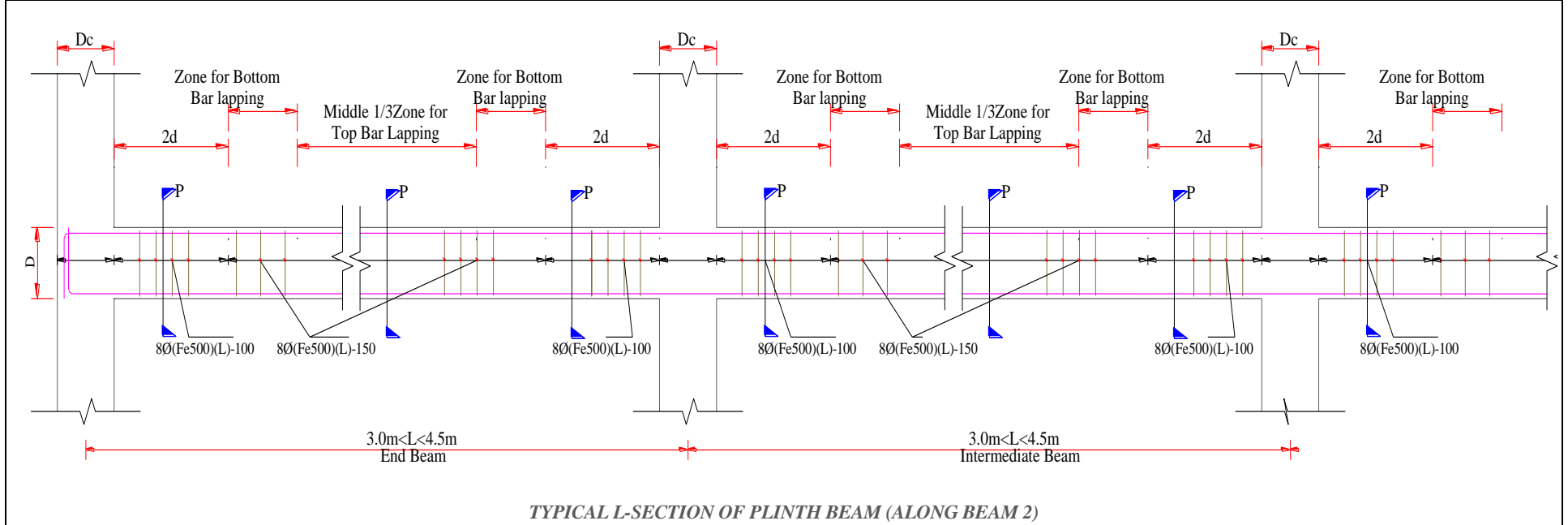
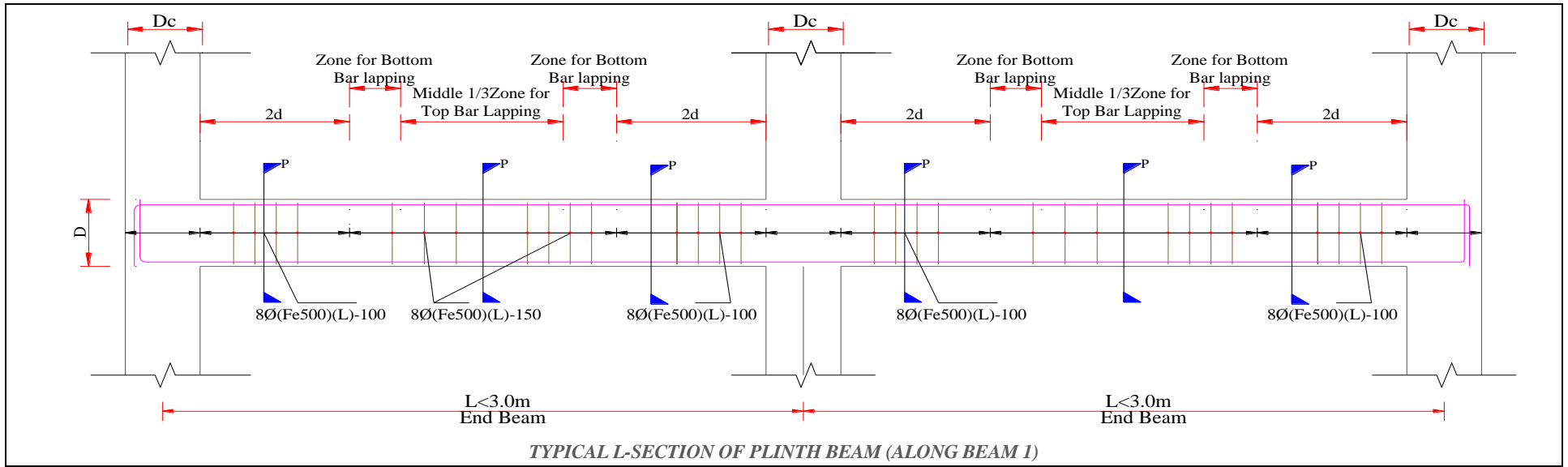
Diameters of Bars Ø (mm)	For Fe 500, $L_d = 57\phi$ (mm)
8	460
10	570
12	690
16	920
20	1150

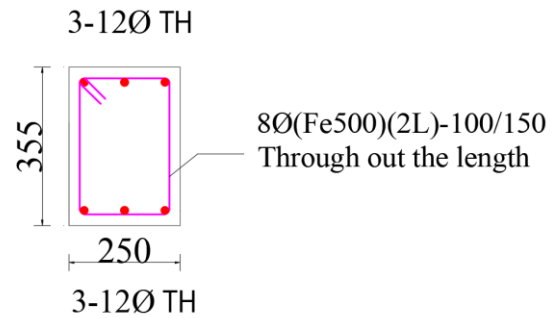
9.3 Beam

This section covers size and reinforcement detail of beam for three storey building with predetermined seismic zoning factor and site sub soil condition.

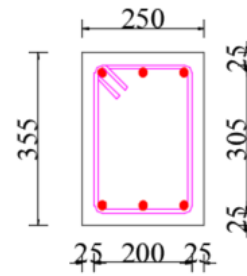
FIGURE 9-5 TYPICAL FLOOR BEAM DETAIL OF THREE STOREY BUILDING



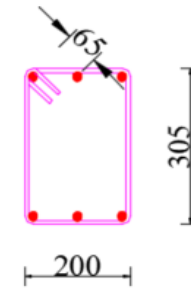




Plinth Tie Beam Section P-P

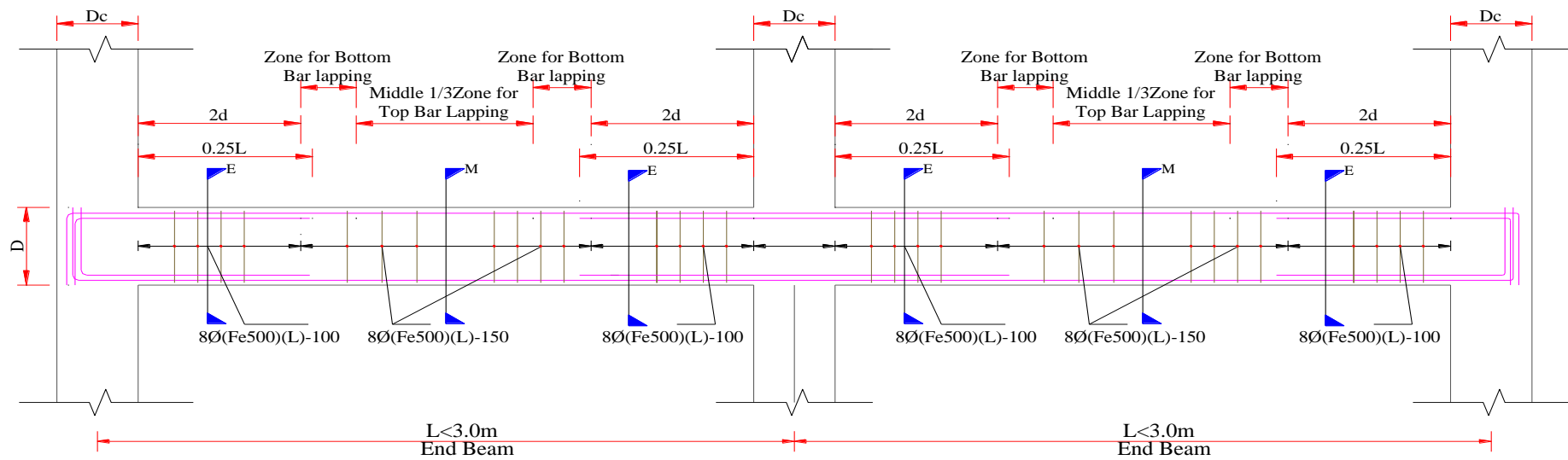


Typical Beam Section P-P

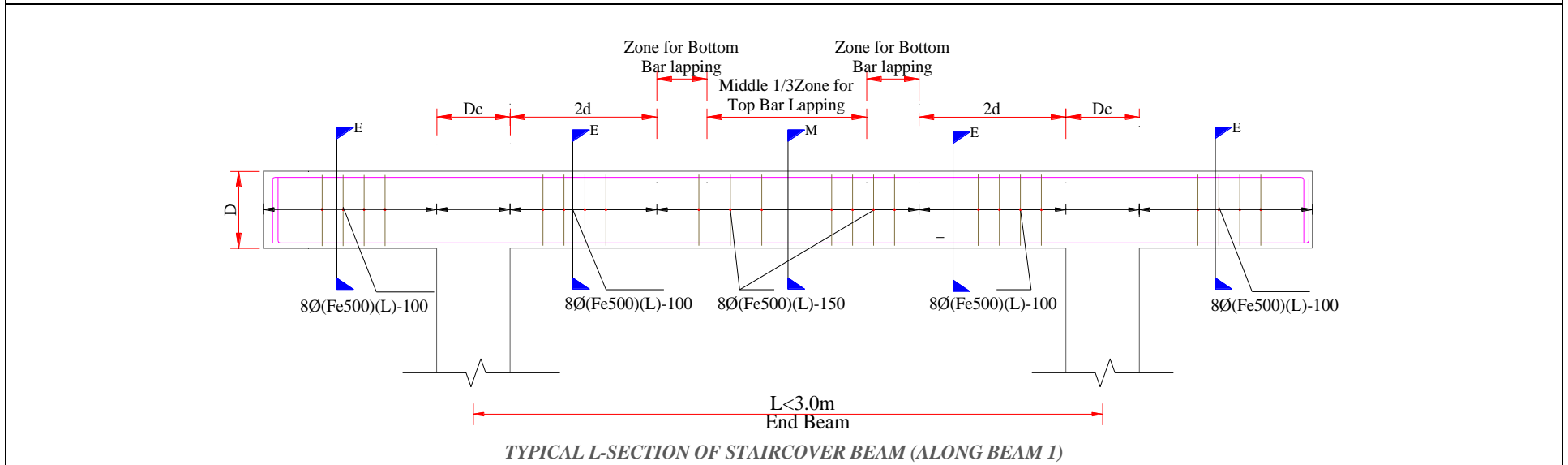
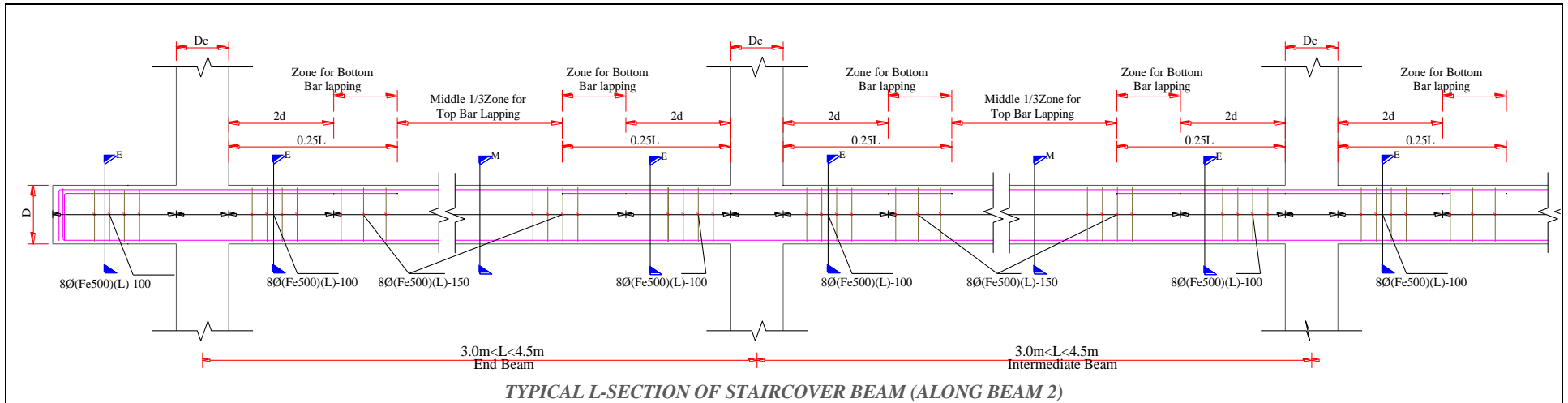


Size of Stirrups of dia 8mm

CROSS-SECTION DETAIL OF PLINTH BEAM



TYPICAL L-SECTION OF FLOOR BEAM (ALONG BEAM 1)



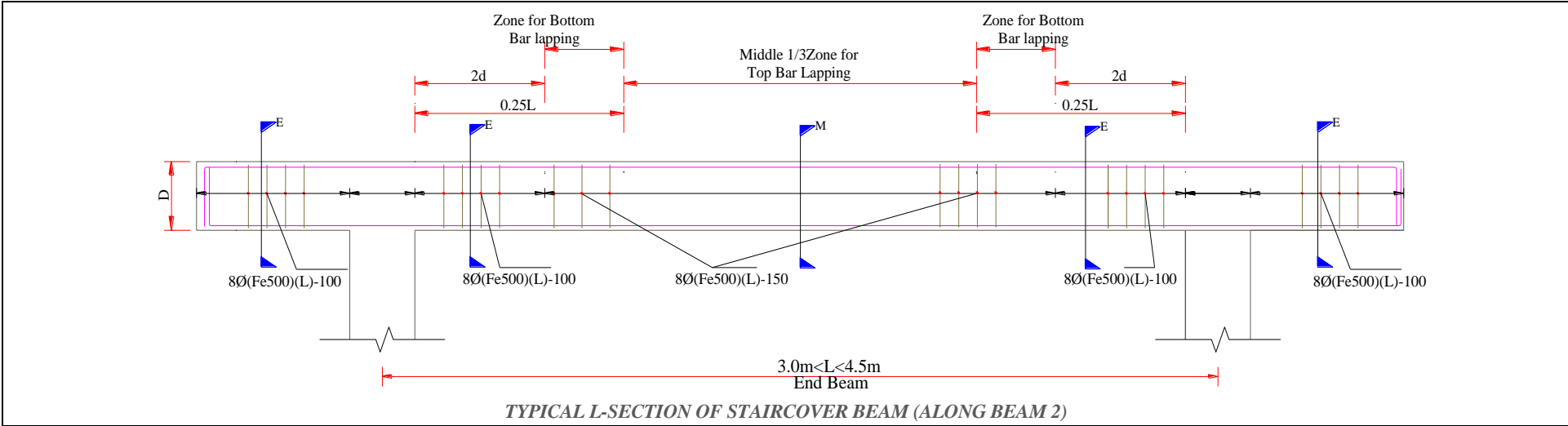
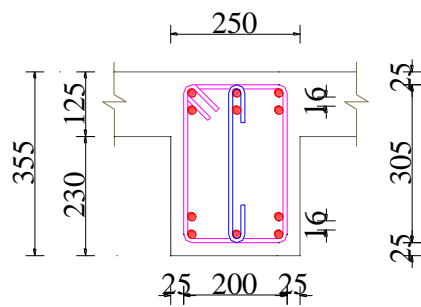


FIGURE 9-6 REINFORCEMENT DISTRIBUTION IN FLOOR BEAM OF THREE STOREY BUILDING

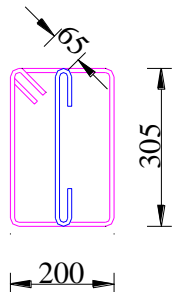
<u>BEAM WIDTH (B) MM</u>	<u>BEAM DEPTH (D) MM</u>	<u>REBAR DISTRIBUTION OF BEAM AT MIDDLE BEAM SECTION (M)</u>	<u>REBAR DISTRIBUTION OF BEAM AT LEFT END/RIGHT END (E)</u>
250	355	<p>Through Bars (TH) At Top Face $8\text{Ø}(\text{Fe}500)(\text{L})-150$ Through Bars (TH) At Bottom Face</p>	<p>Through Bars (TH) At Top Face Extra Bars (EXT) At Top Face $8\text{Ø}(\text{Fe}500)(\text{L})-100$ Extra Bars (EXT) At Bottom Face Through Bars (TH) At Bottom Face</p>
250	380	<p>Through Bars (TH) At Top Face $8\text{Ø}(\text{Fe}500)(\text{L})-150$ Through Bars (TH) At Bottom Face</p>	<p>Through Bars (TH) At Top Face Extra Bars (EXT) At Top Face $8\text{Ø}(\text{Fe}500)(\text{L})-100$ Extra Bars (EXT) At Bottom Face Through Bars (TH) At Bottom Face</p>
300	380	<p>Through Bars (TH) At Top Face $8\text{Ø}(\text{Fe}500)(\text{L})-150$ Through Bars (TH) At Bottom Face</p>	<p>Through Bars (TH) At Top Face Extra Bars (EXT) At Top Face $8\text{Ø}(\text{Fe}500)(\text{L})-100$ Extra Bars (EXT) At Bottom Face Through Bars (TH) At Bottom Face</p>

REBAR DISTRIBUTION OF BEAM AT DIFFERENT SECTION FOR DIFFERENT BEAM SIZES

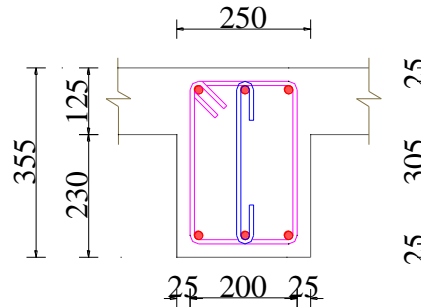
NOTE: EXTRA BARS MAY NOT BE PROVIDED WHEREVER IT IS NOT NECESSARY AS PER BEAM REINFORCEMENT TABLE



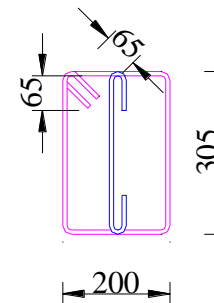
Typical Beam Section
E-E



Size of Stirrups of dia 8mm



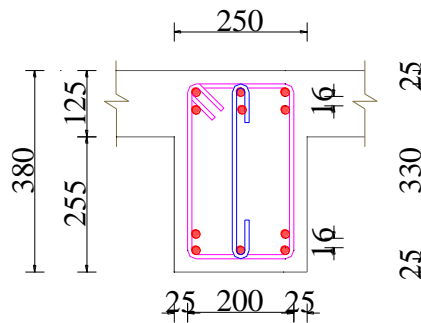
Typical Beam Section
M-M



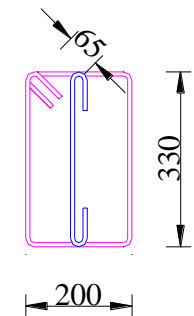
Size of Stirrups of dia 8mm

TYPICAL FLOOR BEAM SECTION AND STIRRUUPS SIZE FOR BEAM SIZE (250MM X 355MM)

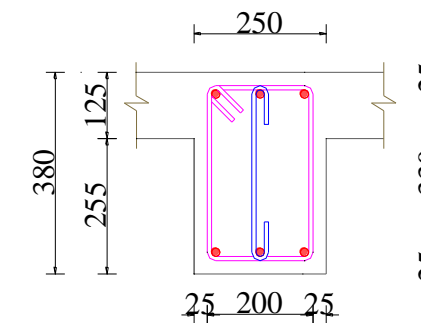
NOTE: EXTRA BARS MAY NOT BE PROVIDED WHEREVER IT IS NOT NECESSARY AS PER BEAM REINFORCEMENT TABLE



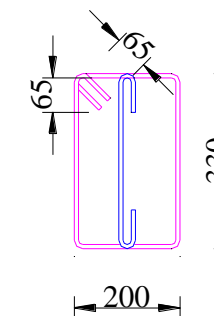
Typical Beam Section
E-E



Size of Stirrups of dia 8mm



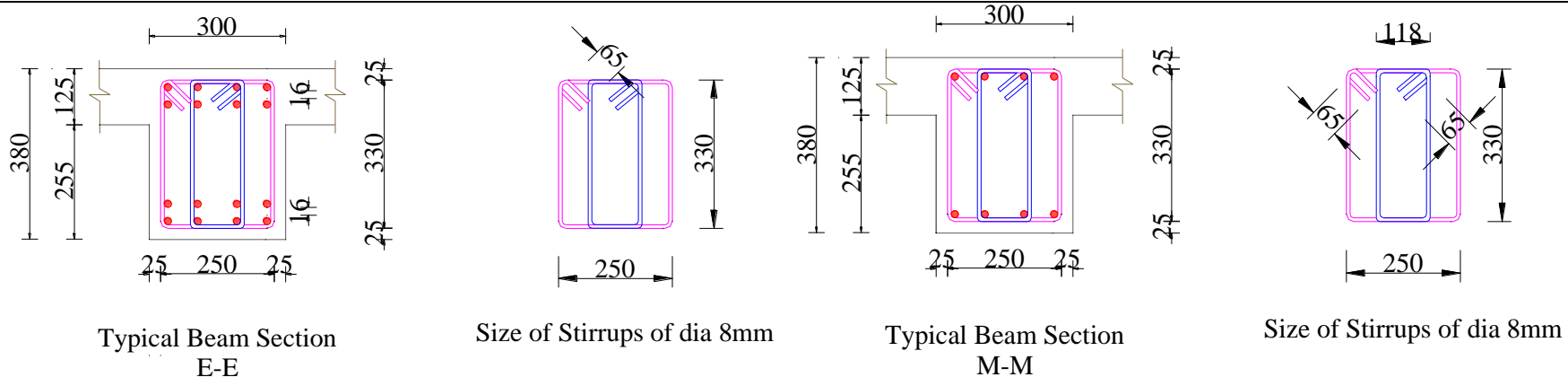
Typical Beam Section
M-M



Size of Stirrups of dia 8mm

TYPICAL BEAM SECTION AND STIRRUUPS SIZE FOR BEAM SIZE (250MM X 380MM)

NOTE: EXTRA BARS MAY NOT BE PROVIDED WHEREVER IT IS NOT NECESSARY AS PER BEAM REINFORCEMENT TABLE



Typical Beam Section
E-E

Size of Stirrups of dia 8mm

Typical Beam Section
M-M

Size of Stirrups of dia 8mm

TYPICAL BEAM SECTION AND STIRRUPS SIZE FOR BEAM SIZE (300MM X 380MM)

NOTE: EXTRA BARS MAY NOT BE PROVIDED WHEREVER IT IS NOT NECESSARY AS PER BEAM REINFORCEMENT TABLE

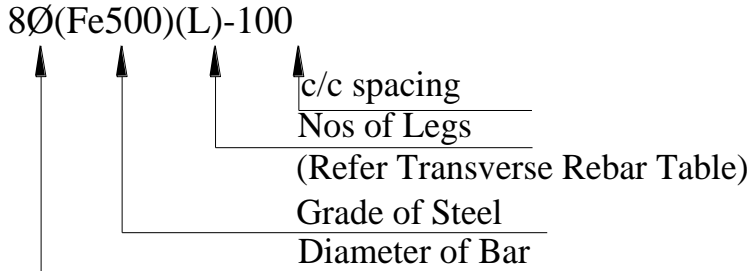
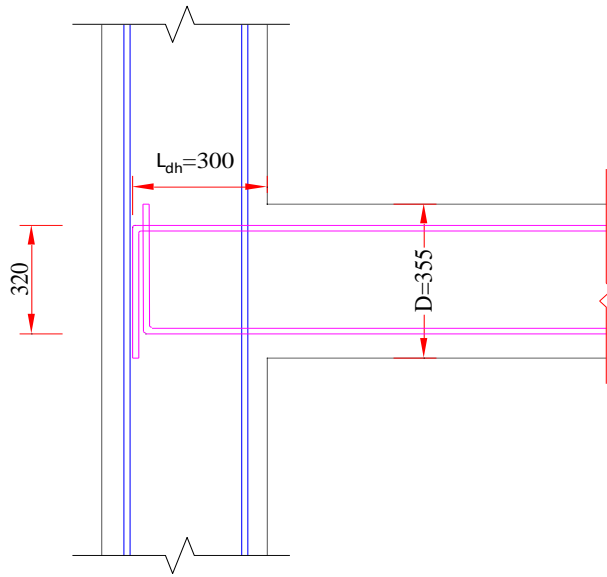
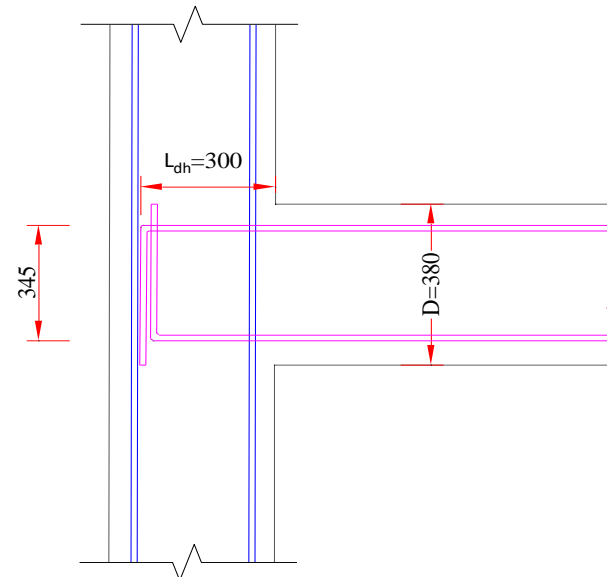


FIGURE 9-7 ANCHORAGE OF LONGITUDINAL BARS OF BEAM IN COLUMN



**ANCHORAGE OF LONGITUDINAL BARS
OF BEAM (DEPTH = 355MM) IN COLUMN**



**ANCHORAGE OF LONGITUDINAL BARS
OF BEAM (DEPTH = 380MM) IN COLUMN**

TABLE 9-11 BEAM REINFORCEMENT DISTRIBUTION OF THREE STOREY BUILDING FOR DIFFERENT SEISMIC ZONES AND SITE SUB SOIL CATEGORIES C

BEAM REBAR DISTRIBUTION TABLE FOR THREE STOREY BUILDING, SEISMIC ZONE FACTOR = 0.25									
SITE SUBSOIL CATEGORY C	FLOOR	Type	Beam Size		Face	Rebar Combination At Left End/ Right End(E)		Rebar Combination At Middle (M)	
			B(mm)	D(mm)		Through Bar (TH)	Extra Bars (EXT)	Through Bar (TH)	
	FIRST FLOOR	BEAM 1		250	355	Top	3-12Ø (TH)	2-12Ø (EXT)	3-12Ø (TH)
				250	355	Bottom	3-12Ø (TH)	2-12Ø (EXT)	3-12Ø (TH)
		BEAM 2		250	355	Top	3-12Ø (TH)	2-12Ø (EXT)	3-12Ø (TH)
				250	355	Bottom	3-12Ø (TH)	-	3-12Ø (TH)
	SECOND FLOOR	BEAM 1		250	355	Top	3-12Ø (TH)	2-12Ø (EXT)	3-12Ø (TH)
				250	355	Bottom	3-12Ø (TH)	-	3-12Ø (TH)
		BEAM 2		250	355	Top	3-12Ø (TH)	2-12Ø (EXT)	3-12Ø (TH)
				250	355	Bottom	3-12Ø (TH)	-	3-12Ø (TH)
THIRD FLOOR	BEAM 1		250	355	Top	3-12Ø (TH)	-	3-12Ø (TH)	
			250	355	Bottom	3-12Ø (TH)	-	3-12Ø (TH)	
	BEAM 2		250	355	Top	3-12Ø (TH)	-	3-12Ø (TH)	
			250	355	Bottom	3-12Ø (TH)	-	3-12Ø (TH)	
STAIRCOVER	BEAM 1		250	355	Top	3-12Ø (TH)	-	3-12Ø (TH)	
			250	355	Bottom	3-12Ø (TH)	-	3-12Ø (TH)	
	BEAM 2		250	355	Top	3-12Ø (TH)	-	3-12Ø (TH)	
			250	355	Bottom	3-12Ø (TH)	-	3-12Ø (TH)	

BEAM 1	Beam of span upto 3m	BEAM 2	Beam of span greater than 3m and upto 4.5 m
---------------	----------------------	---------------	---

BEAM REBAR DISTRIBUTION TABLE FOR THREE STOREY BUILDING, SEISMIC ZONE FACTOR = 0.3

SITE SUBSOIL CATEGORY C	FLOOR	Type	Beam Size		Face	Rebar Combination At Left End/ Right End(E)		Rebar Combination At Middle (M)	
			B(mm)	D(mm)		Through Bar (TH)	Extra Bars (EXT)	Through Bar (TH)	
FIRST FLOOR	BEAM 1	Top	250	380	Top	3-12Ø (TH)	3-12Ø (EXT)	3-12Ø (TH)	
		Bottom	250	380	Bottom	3-12Ø (TH)	2-12Ø (EXT)	3-12Ø (TH)	
	BEAM 2	Top	250	380	Top	3-12Ø (TH)	2-12Ø (EXT)	3-12Ø (TH)	
		Bottom	250	380	Bottom	3-12Ø (TH)	-	3-12Ø (TH)	
	SECOND FLOOR	BEAM 1	Top	250	355	Top	3-12Ø (TH)	2-12Ø (EXT)	3-12Ø (TH)
			Bottom	250	355	Bottom	3-12Ø (TH)	2-12Ø (EXT)	3-12Ø (TH)
		BEAM 2	Top	250	355	Top	3-12Ø (TH)	2-12Ø (EXT)	3-12Ø (TH)
Bottom			250	355	Bottom	3-12Ø (TH)	-	3-12Ø (TH)	
THIRD FLOOR	BEAM 1	Top	250	355	Top	3-12Ø (TH)	-	3-12Ø (TH)	
		Bottom	250	355	Bottom	3-12Ø (TH)	-	3-12Ø (TH)	
	BEAM 2	Top	250	355	Top	3-12Ø (TH)	-	3-12Ø (TH)	
		Bottom	250	355	Bottom	3-12Ø (TH)	-	3-12Ø (TH)	
STAIRCOVER	BEAM 1	Top	250	355	Top	3-12Ø (TH)	-	3-12Ø (TH)	
		Bottom	250	355	Bottom	3-12Ø (TH)	-	3-12Ø (TH)	
	BEAM 2	Top	250	355	Top	3-12Ø (TH)	-	3-12Ø (TH)	
		Bottom	250	355	Bottom	3-12Ø (TH)	-	3-12Ø (TH)	

BEAM 1	Beam of span upto 3m	BEAM 2	Beam of span greater than 3m and upto 4.5 m
---------------	----------------------	---------------	---

BEAM REBAR DISTRIBUTION TABLE FOR THREE STOREY BUILDING, SEISMIC ZONE FACTOR = 0.35

SITE SUBSOIL CATEGORY C	FLOOR	Type	Beam Size		Face	Rebar Combination At Left End/ Right End(E)		Rebar Combination At Middle (M)
			B(mm)	D(mm)		Through Bar (TH)	Extra Bars (EXT)	Through Bar (TH)
FIRST FLOOR	BEAM 1		250	380	Top	3-12Ø (TH)	3-12Ø (EXT)	3-12Ø (TH)
			250	380	Bottom	3-12Ø (TH)	2-12Ø (EXT)	3-12Ø (TH)
	BEAM 2		250	380	Top	3-12Ø (TH)	3-12Ø (EXT)	3-12Ø (TH)
			250	380	Bottom	3-12Ø (TH)	-	3-12Ø (TH)
SECOND FLOOR	BEAM 1		250	355	Top	3-12Ø (TH)	2-12Ø (EXT)	3-12Ø (TH)
			250	355	Bottom	3-12Ø (TH)	2-12Ø (EXT)	3-12Ø (TH)
	BEAM 2		250	355	Top	3-12Ø (TH)	2-12Ø (EXT)	3-12Ø (TH)
			250	355	Bottom	3-12Ø (TH)	-	3-12Ø (TH)
THIRD FLOOR	BEAM 1		250	355	Top	3-12Ø (TH)	-	3-12Ø (TH)
			250	355	Bottom	3-12Ø (TH)	-	3-12Ø (TH)
	BEAM 2		250	355	Top	3-12Ø (TH)	-	3-12Ø (TH)
			250	355	Bottom	3-12Ø (TH)	-	3-12Ø (TH)
STAIRCOVER	BEAM 1		250	355	Top	3-12Ø (TH)	-	3-12Ø (TH)
			250	355	Bottom	3-12Ø (TH)	-	3-12Ø (TH)
	BEAM 2		250	355	Top	3-12Ø (TH)	-	3-12Ø (TH)
			250	355	Bottom	3-12Ø (TH)	-	3-12Ø (TH)

BEAM 1	Beam of span upto 3m	BEAM 2	Beam of span greater than 3m and upto 4.5 m
---------------	----------------------	---------------	---

BEAM REBAR DISTRIBUTION TABLE FOR THREE STOREY BUILDING, SEISMIC ZONE FACTOR = 0.4

SITE SUBSOIL CATEGORY C	FLOOR	Type	Beam Size		Face	Rebar Combination At Left End/ Right End(E)		Rebar Combination At Middle (M)
			B(mm)	D(mm)		Through Bar (TH)	Extra Bars (EXT)	Through Bar (TH)
SITE SUBSOIL CATEGORY C	FIRST FLOOR	BEAM 1	300	380	Top	4-12Ø (TH)	4-12Ø (EXT)	4-12Ø (TH)
			300	380	Bottom	4-12Ø (TH)	4-12Ø (EXT)	4-12Ø (TH)
		BEAM 2	300	380	Top	4-12Ø (TH)	4-12Ø (EXT)	4-12Ø (TH)
			300	380	Bottom	4-12Ø (TH)	2-12Ø (EXT)	4-12Ø (TH)
	SECOND FLOOR	BEAM 1	250	355	Top	3-12Ø (TH)	3-12Ø (EXT)	3-12Ø (TH)
			250	355	Bottom	3-12Ø (TH)	2-12Ø (EXT)	3-12Ø (TH)
		BEAM 2	250	355	Top	3-12Ø (TH)	3-12Ø (EXT)	3-12Ø (TH)
			250	355	Bottom	3-12Ø (TH)	-	3-12Ø (TH)
THIRD FLOOR	BEAM 1	250	355	Top	3-12Ø (TH)	2-12Ø (EXT)	3-12Ø (TH)	
		250	355	Bottom	3-12Ø (TH)	-	3-12Ø (TH)	
	BEAM 2	250	355	Top	3-12Ø (TH)	2-12Ø (EXT)	3-12Ø (TH)	
		250	355	Bottom	3-12Ø (TH)	-	3-12Ø (TH)	
STAIRCOVER	BEAM 1	250	355	Top	3-12Ø (TH)	-	3-12Ø (TH)	
		250	355	Bottom	3-12Ø (TH)	-	3-12Ø (TH)	
	BEAM 2	250	355	Top	3-12Ø (TH)	-	3-12Ø (TH)	
		250	355	Bottom	3-12Ø (TH)	-	3-12Ø (TH)	

BEAM 1	Beam of span upto 3m	BEAM 2	Beam of span greater than 3m and upto 4.5 m
---------------	----------------------	---------------	---

**TABLE 9-12 BEAM REINFORCEMENT DISTRIBUTION OF THREE STOREY BUILDING FOR
0.35 SEISMIC ZONE AND SITE SUB SOIL CATEGORY D**

BEAM REBAR DISTRIBUTION TABLE FOR THREE STOREY BUILDING, SEISMIC ZONE FACTOR = 0.35									
SITE SUBSOIL CATEGORY D	FLOOR	Type	Beam Size		Face	Rebar Combination At Left End/ Right End(E)		Rebar Combination At Middle (M)	
			B(mm)	D(mm)		Through Bar (TH)	Extra Bars (EXT)	Through Bar (TH)	
	FIRST FLOOR	BEAM 1		250	380	Top	3-12Ø (TH)	3-12Ø (EXT)	3-12Ø (TH)
				250	380	Bottom	3-12Ø (TH)	2-12Ø (EXT)	3-12Ø (TH)
		BEAM 2		250	380	Top	3-12Ø (TH)	2-12Ø (EXT)	3-12Ø (TH)
				250	380	Bottom	3-12Ø (TH)	-	3-12Ø (TH)
	SECOND FLOOR	BEAM 1		250	355	Top	3-12Ø (TH)	2-12Ø (EXT)	3-12Ø (TH)
				250	355	Bottom	3-12Ø (TH)	2-12Ø (EXT)	3-12Ø (TH)
		BEAM 2		250	355	Top	3-12Ø (TH)	2-12Ø (EXT)	3-12Ø (TH)
				250	355	Bottom	3-12Ø (TH)	-	3-12Ø (TH)
THIRD FLOOR	BEAM 1		250	355	Top	3-12Ø (TH)	-	3-12Ø (TH)	
			250	355	Bottom	3-12Ø (TH)	-	3-12Ø (TH)	
	BEAM 2		250	355	Top	3-12Ø (TH)	-	3-12Ø (TH)	
			250	355	Bottom	3-12Ø (TH)	-	3-12Ø (TH)	
STAIRCOVER	BEAM 1		250	355	Top	3-12Ø (TH)	-	3-12Ø (TH)	
			250	355	Bottom	3-12Ø (TH)	-	3-12Ø (TH)	
	BEAM 2		250	355	Top	3-12Ø (TH)	-	3-12Ø (TH)	
			250	355	Bottom	3-12Ø (TH)	-	3-12Ø (TH)	

BEAM 1	Beam of span upto 3m	BEAM 2	Beam of span greater than 3m and upto 4.5 m
---------------	----------------------	---------------	---

[Notes:

- i. Fe 500 (TMT) grade steel shall be used for all longitudinal reinforcements and stirrups/closed tie in beams and concrete grade shall be M20 for all beams.
- ii. Clear cover to stirrups in beams shall be 25mm.
- iii. In beam detail, **M** represents **Middle Beam Section**, **E** represents **Left End/ Right End**; **TH** represents **Throughout Bars** and **EXT** represents **Extra Bars**.
- iv. Beam sizes and reinforcement details for pre-determined seismic zone and site subsoil category according to two storey building shall be adopted from **Table 9-11 & Table 9-12**. In a continuous junction of a beam, extra bars from beam section (left/right) shall be continued to adjacent beam section.
- v. Rebar distribution in beam shall be followed from **Figure 9-5** and as per sizes mentioned as per **Table 9-11 & Table 9-12**.
- vi. Top and bottom extra bars shall be curtailed 0.3L away from support but for span less than minimum span of 2.1 m, extra bars shall not be curtailed.
- vii. Lapping of top and bottom bar is allowed only in the zone shown in typical floor beam drawing in **Figure 9-4** and not more than 50% of the bars should be spliced at a section.
- viii. Anchorage of longitudinal reinforcement of beam shall be followed as in **Figure 9-6**.
- ix. Transverse reinforcement in beam shall be adopted **Figure 9-4** in conjunction with **Table 9-13**.
- x. In normal circumstances formwork of slab and beam can be removed after 3 weeks of concreting.
- xi. Lapping of bars shall not be less than 57ϕ or as in **Table 9-10**.
- xii. All stirrups are of closed type and 135° hook should be used with minimum hook length of 65mm.]

Transverse Stirrups:

TABLE 9-13 TRANSVERSE STIRRUPS/TIES IN BEAMS

Zone Floor Level	Beam Size (mm)	End & Lapping Zone	Mid Zone
Stair-cover	250 x 355	3-Legged 8 Ø @ 100 mm c/c	3-Legged 8 Ø @ 150 mm c/c
Third Floor	250 x 355	3-Legged 8 Ø @ 100 mm c/c	3-Legged 8 Ø @ 150 mm c/c
Second Floor	250 x 355	3-Legged 8 Ø @ 100 mm c/c	3-Legged 8 Ø @ 150 mm c/c
First Floor	250 x 355	3-Legged 8 Ø @ 100 mm c/c	3-Legged 8 Ø @ 150 mm c/c
	250 x 380	3-Legged 8 Ø @ 100 mm c/c	3-Legged 8 Ø @ 150 mm c/c
	300 x 380	4-Legged 8 Ø @ 100 mm c/c	4-Legged 8 Ø @ 150 mm c/c
Plinth Beam	250 x 355	2-Legged 8 Ø @ 100 mm c/c	2-Legged 8 Ø @ 150 mm c/c

[Note:

1. All stirrups and ties are of closed type.
2. All closed stirrups shall have 135° Hook and closed tie shall have 180° with minimum hook length of 65mm.]

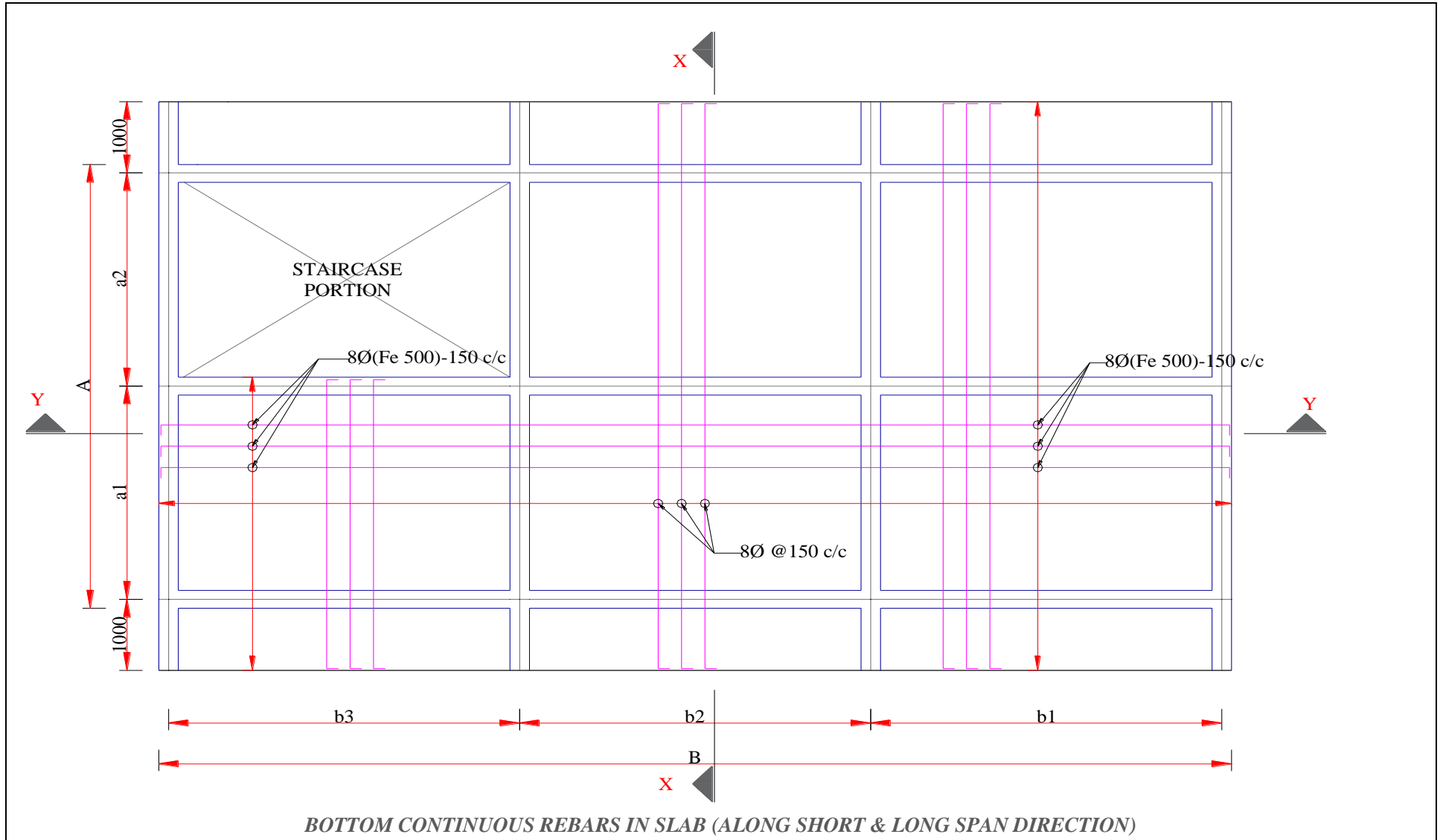
10. Slab and Staircase

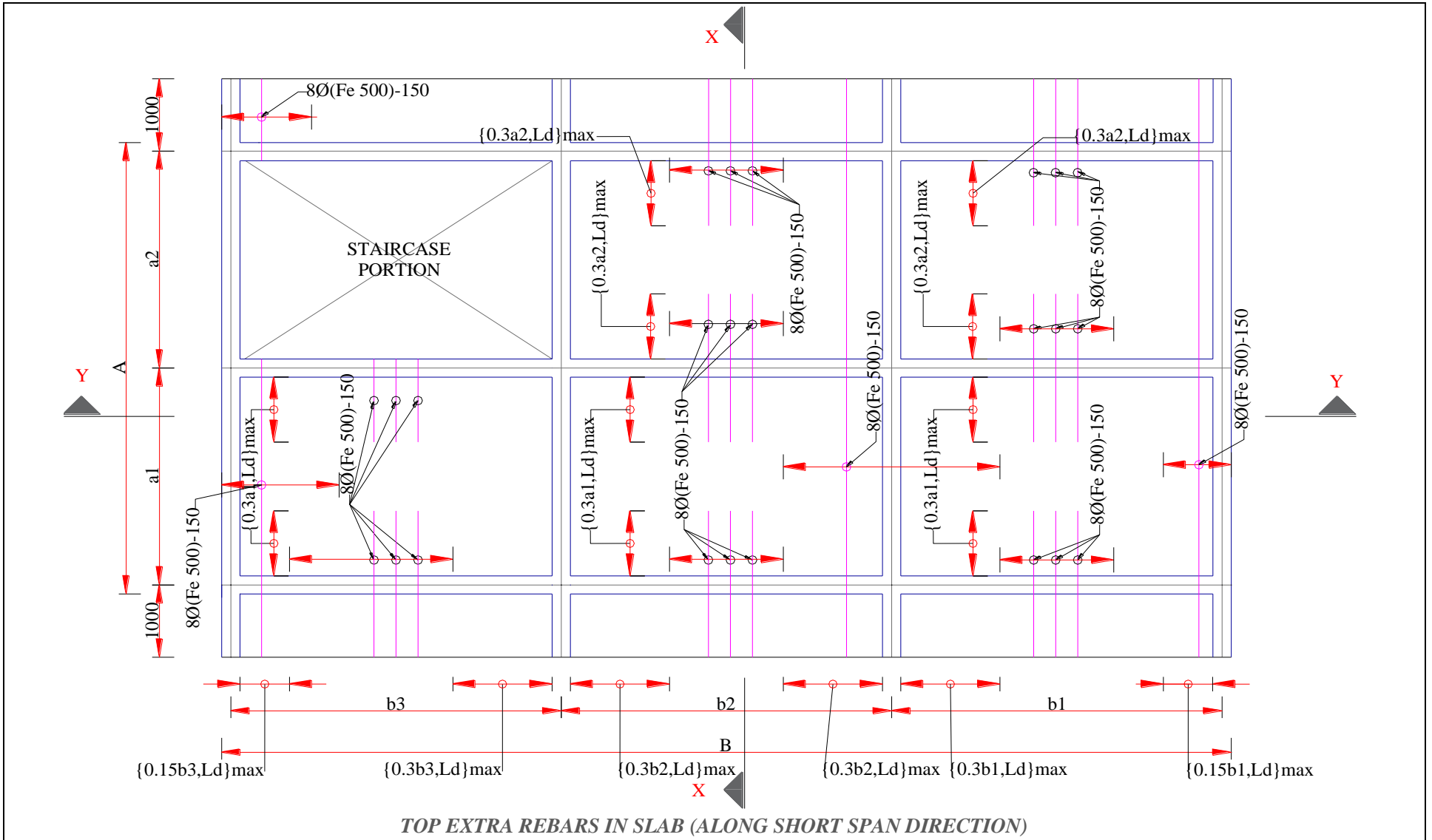
This section covers the size and reinforcement detailing of slab and staircase of building covered by this RUD with limitation as stated in **CI 4.2.**

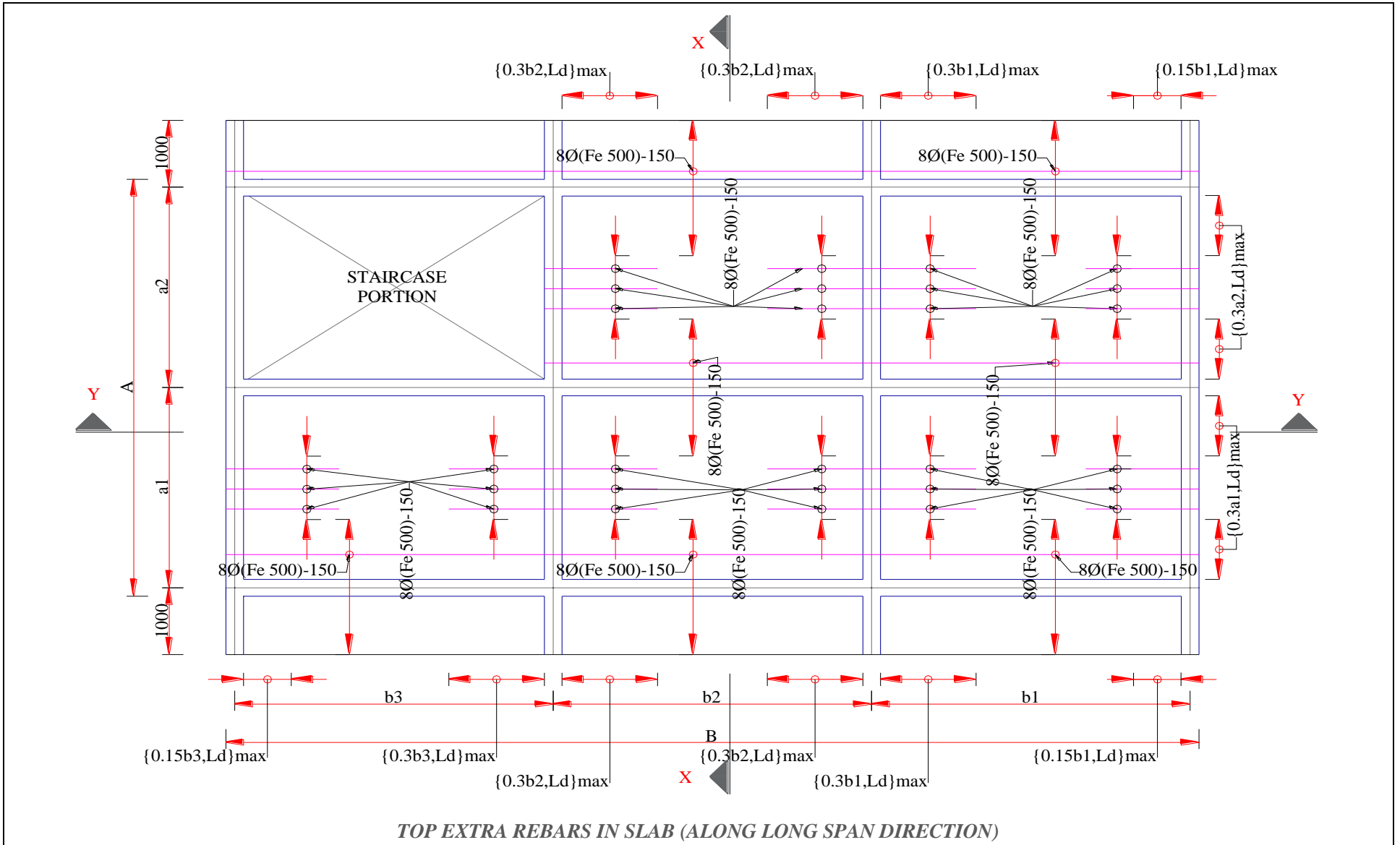
10.1 Slab

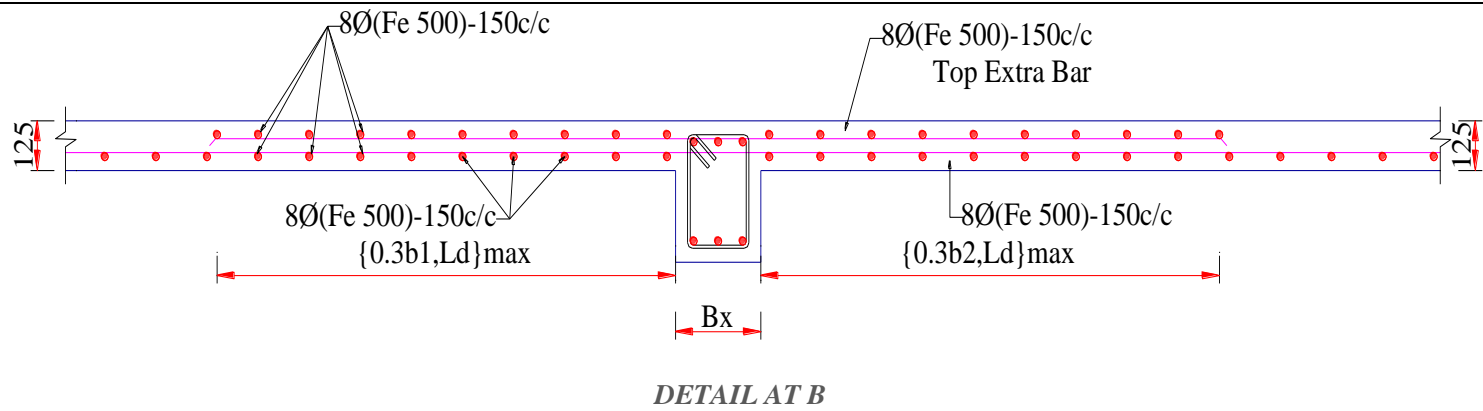
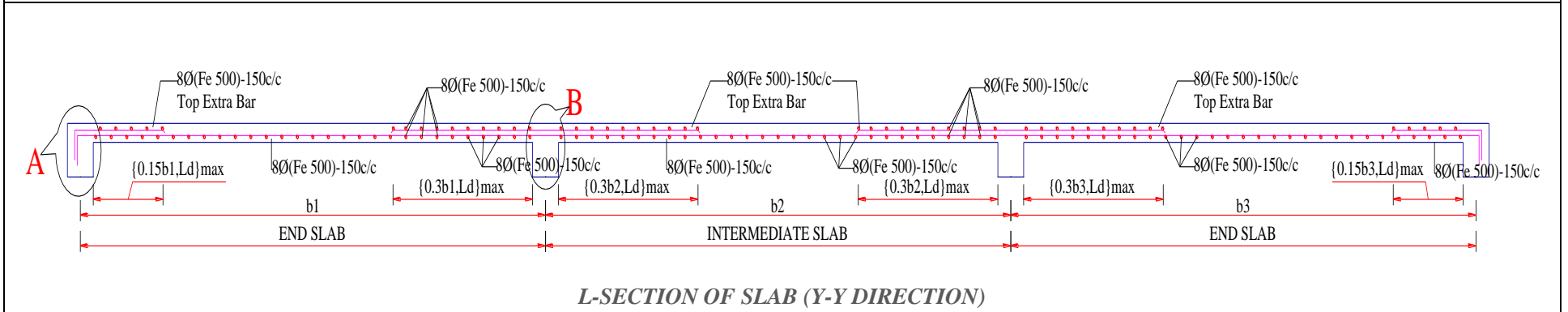
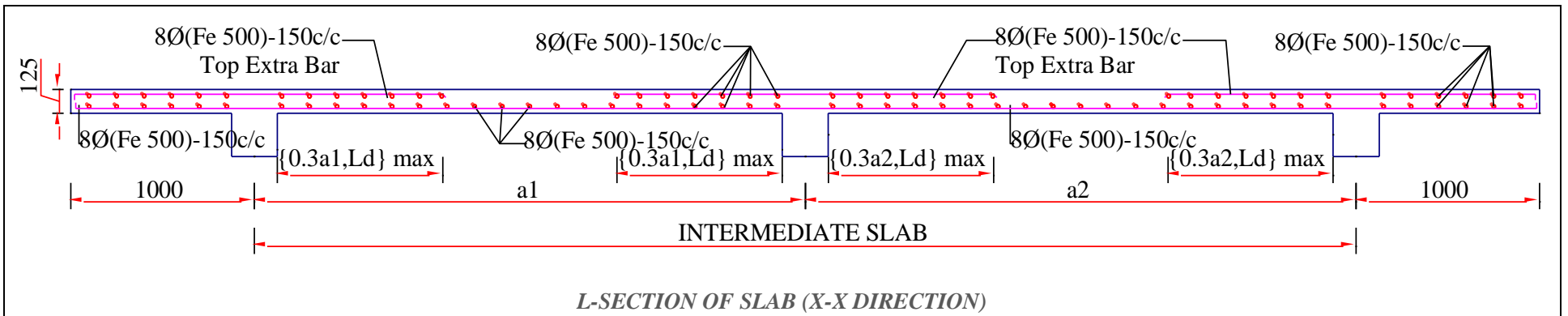
Two options are presented for reinforcement detailing in this RUD. Any of the two options should be used depending upon availability of workmanship and general practice being adopted for construction.

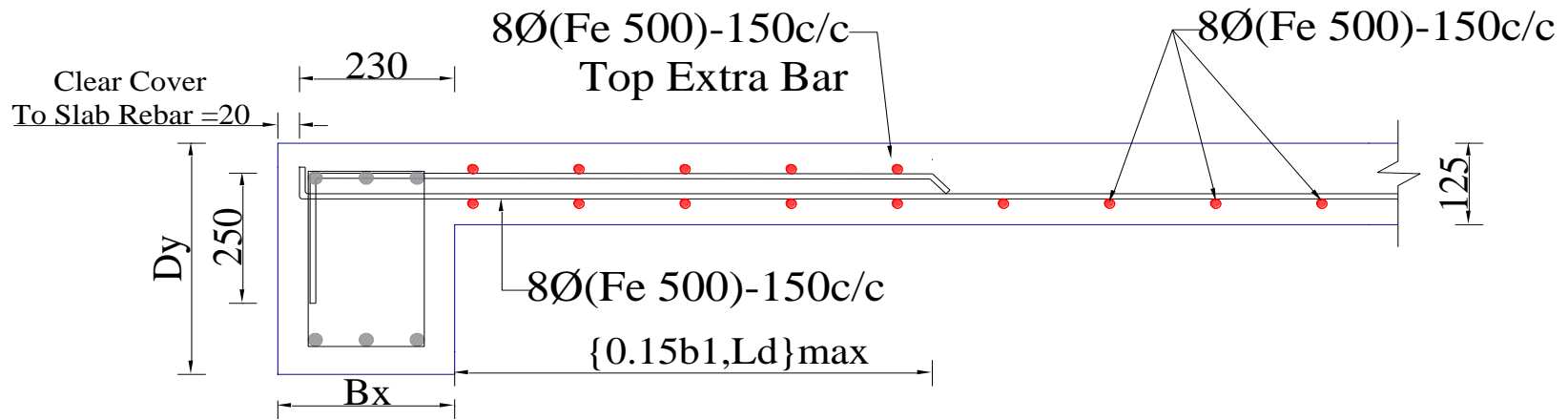
FIGURE 10-1 TYPICAL FLOOR SLAB DETAIL (OPTION I)



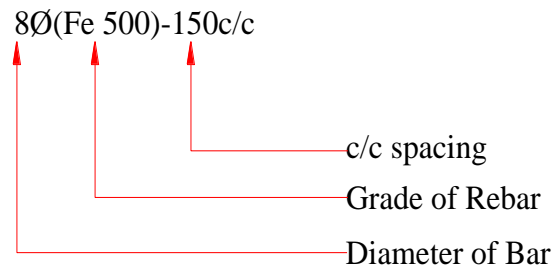






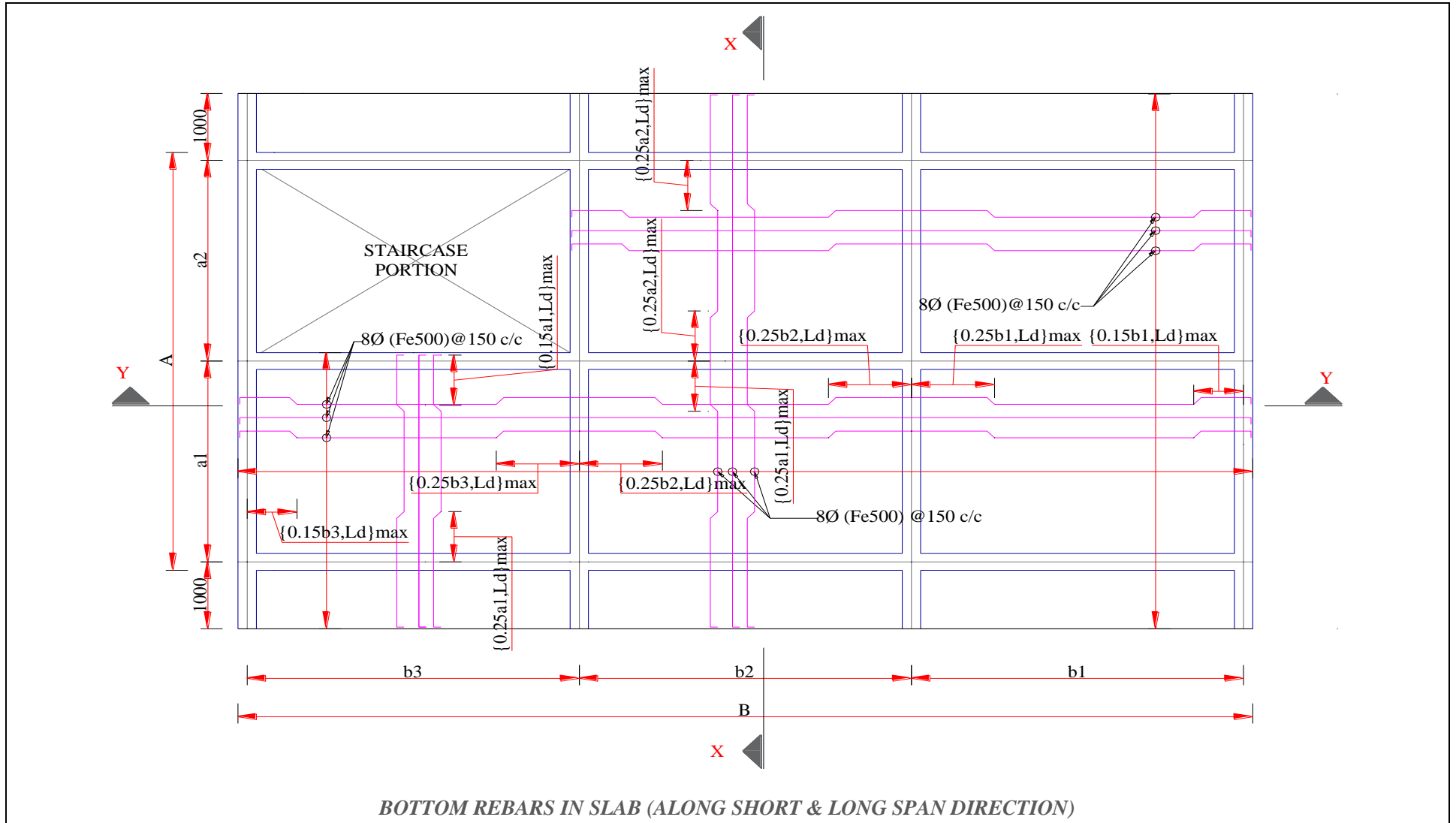


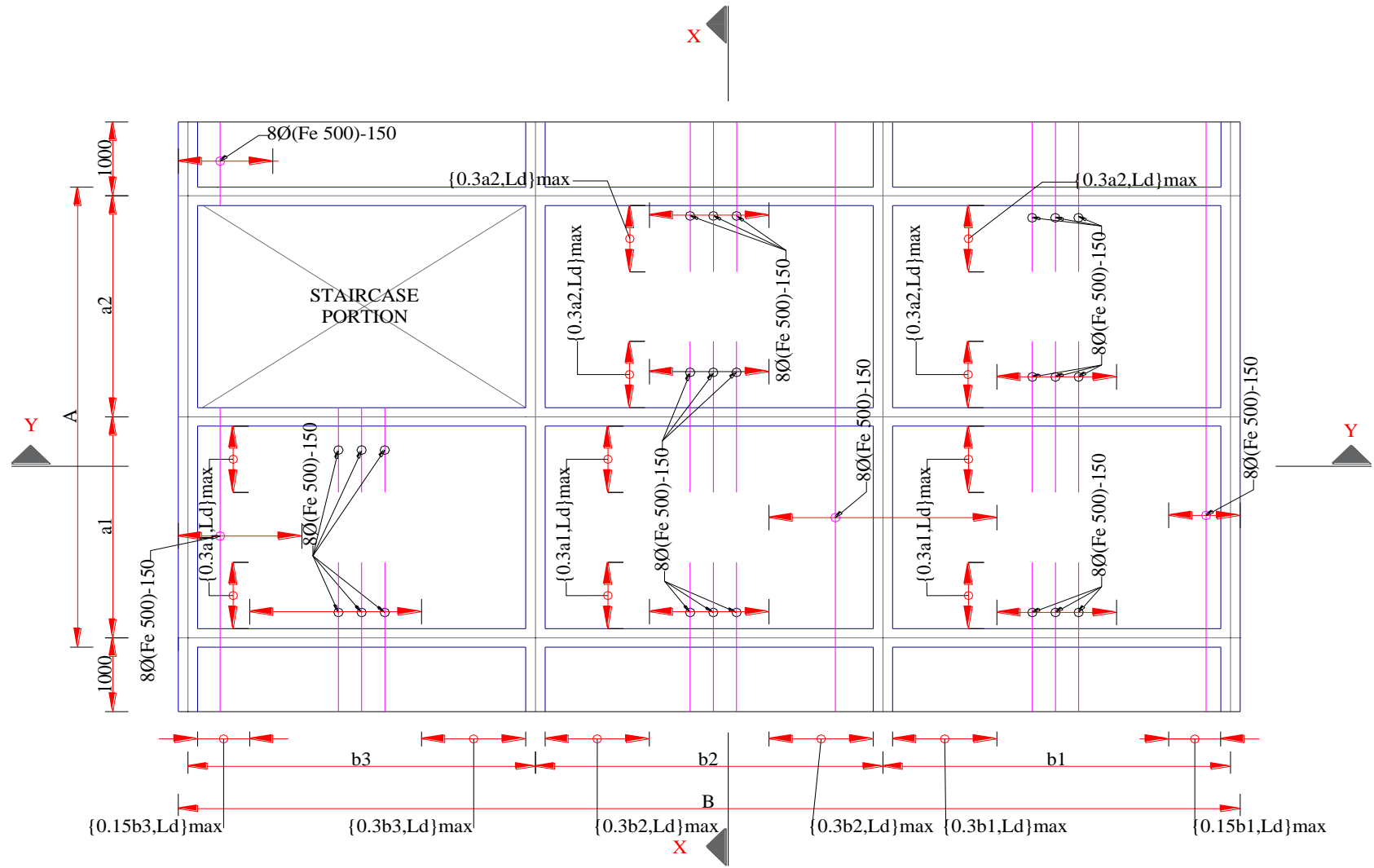
DETAIL AT A



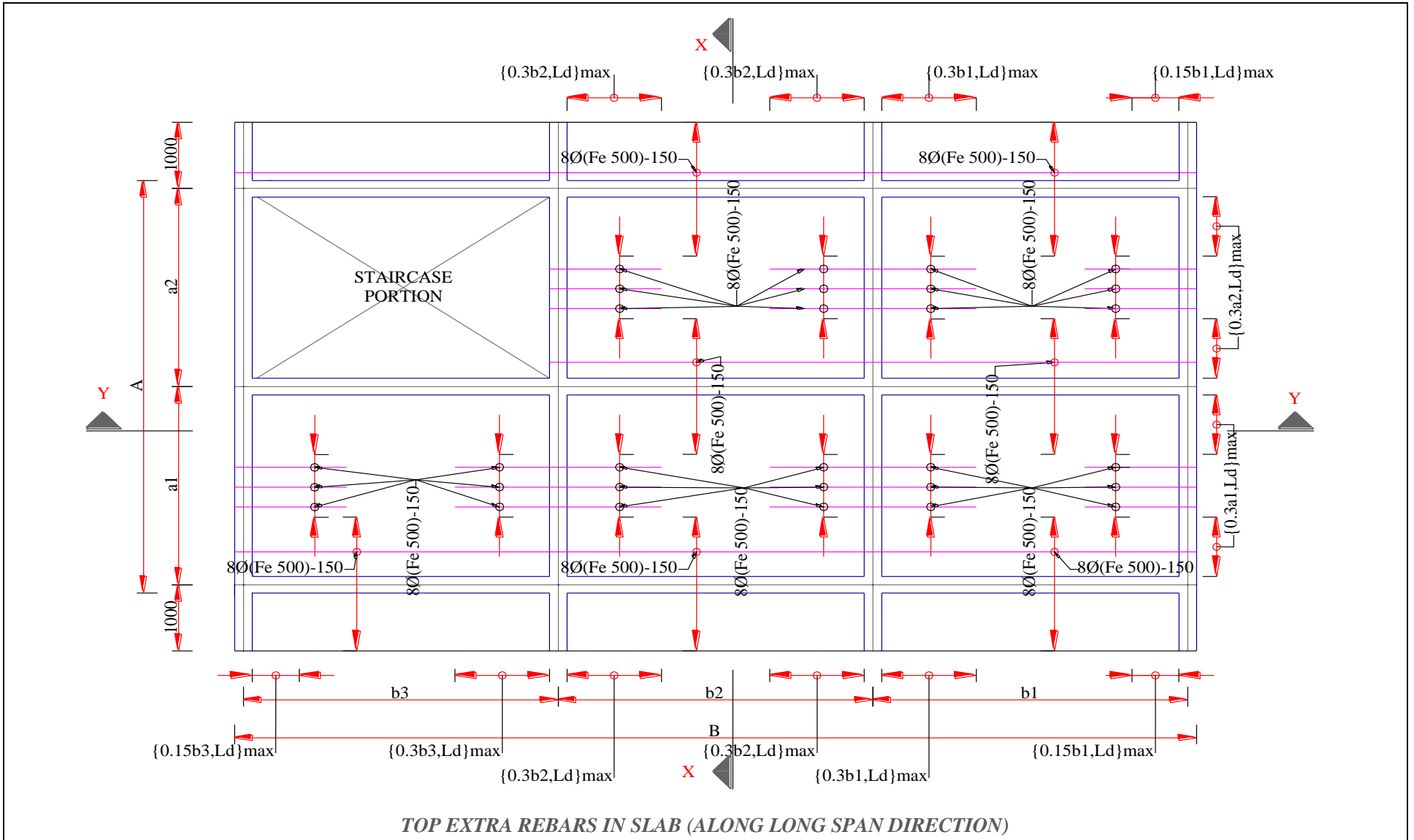
NOTATION FOR REBAR DISTRIBUTION

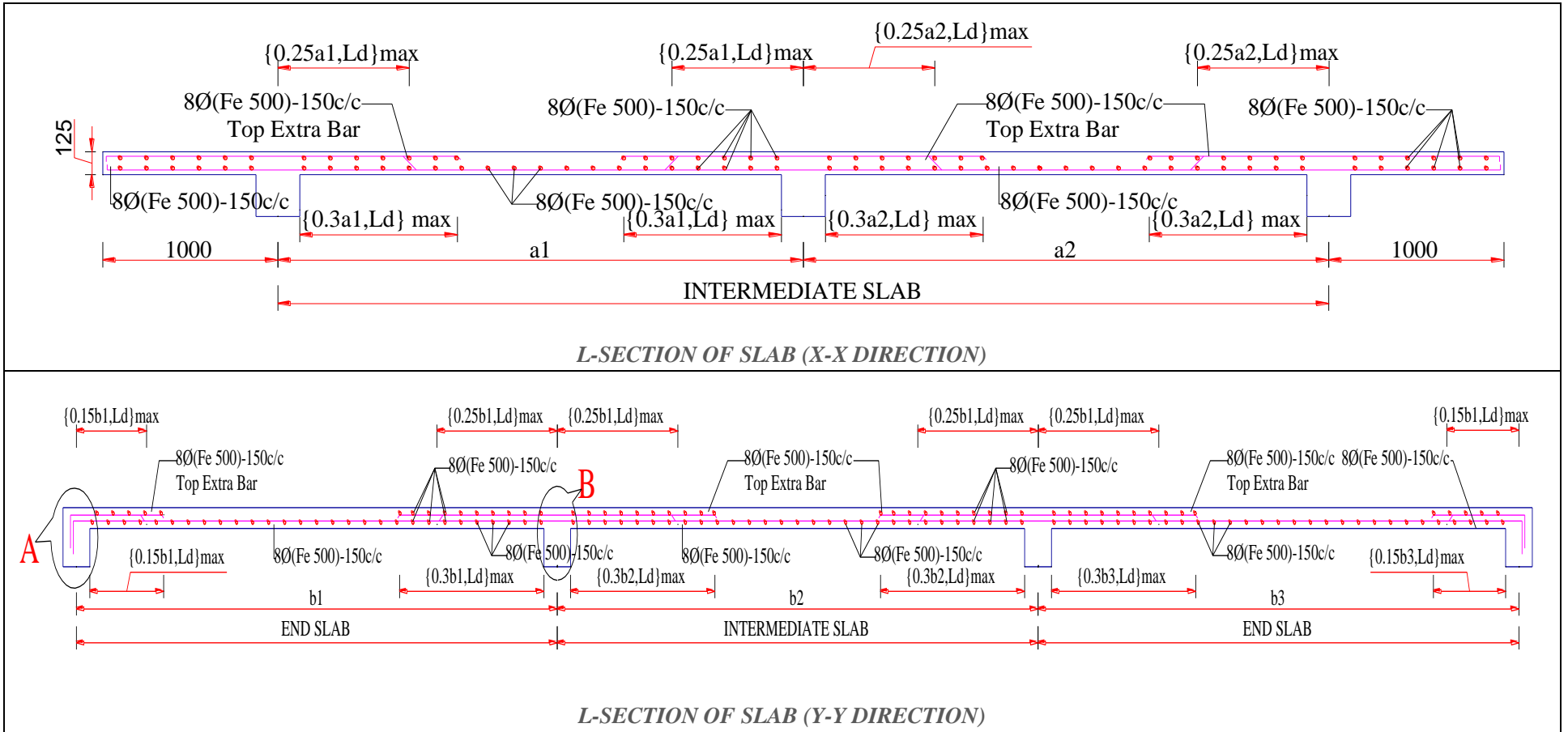
FIGURE 10-2 TYPICAL FLOOR SLAB DETAIL (OPTION II)

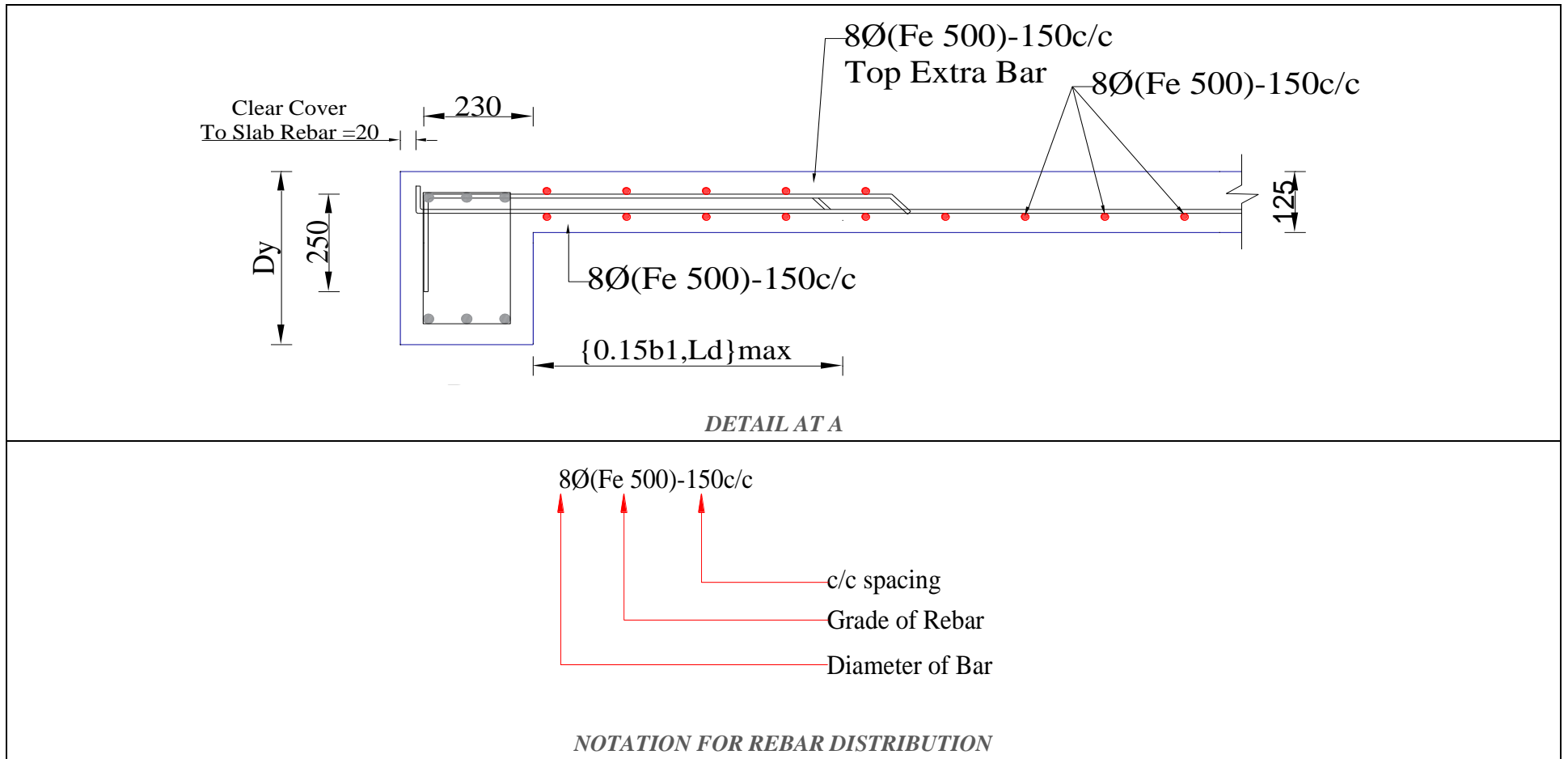




TOP EXTRA REBARS IN SLAB (ALONG SHORT SPAN DIRECTION)







[Note:

- i. Fe 500 (TMT) grade steel shall be used for all longitudinal reinforcements and concrete grade shall be M20 for all slab..
- ii. Clear cover to stirrups in beams shall be 20mm.]

10.2 Staircase

Staircase shall be constructed as dog-legged type as shown in **Figure 10-3** and detailed as shown in **Figure 10-4** & **Figure 10-5**.

FIGURE 10-3 STAIRCASE LAYOUT OPTION AND LANDING BEAM ARRANGEMENT

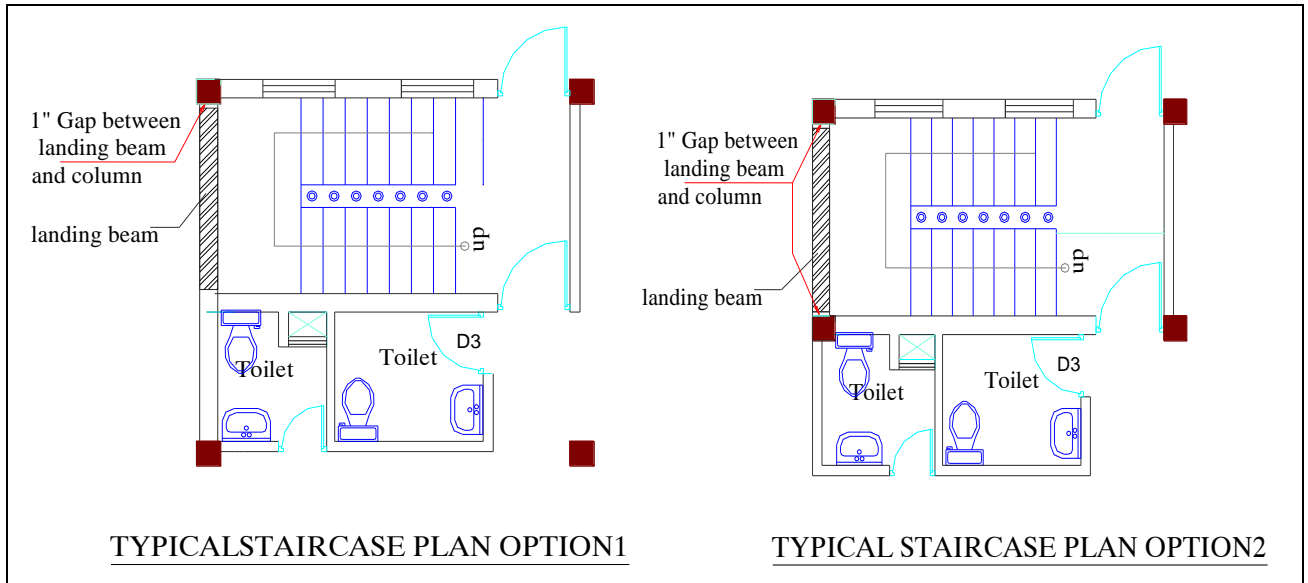
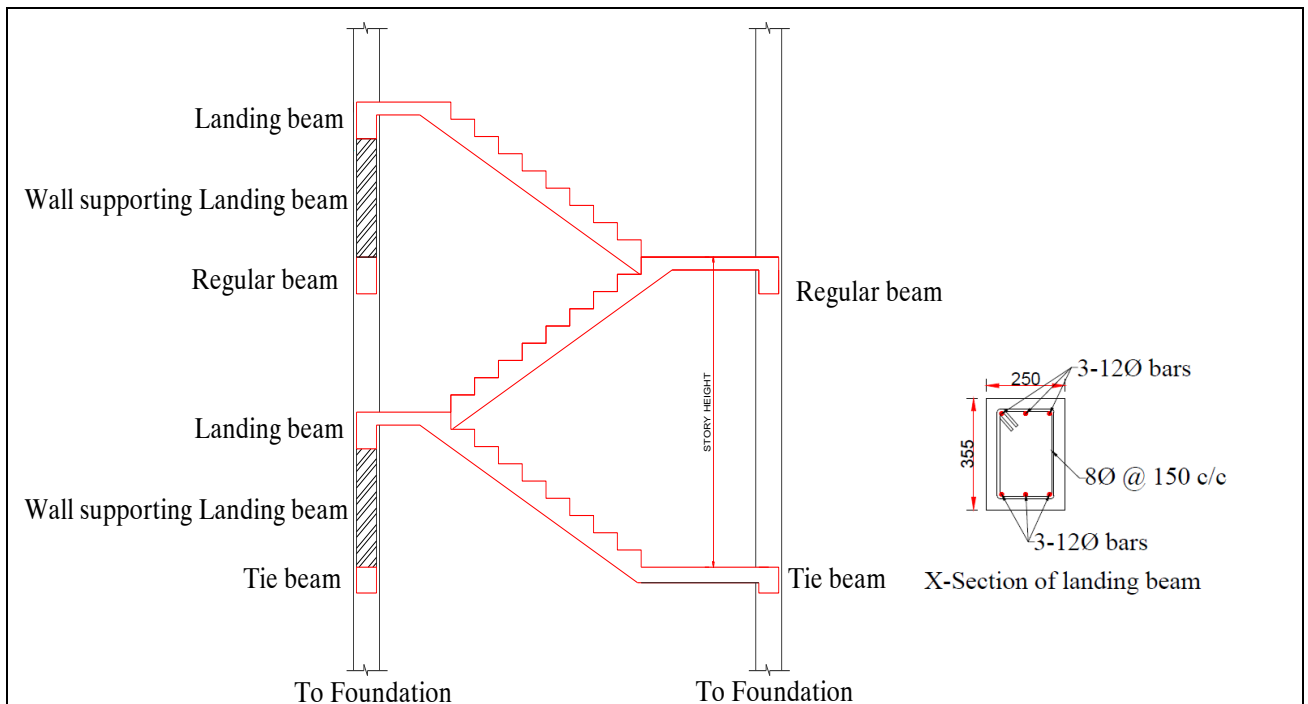


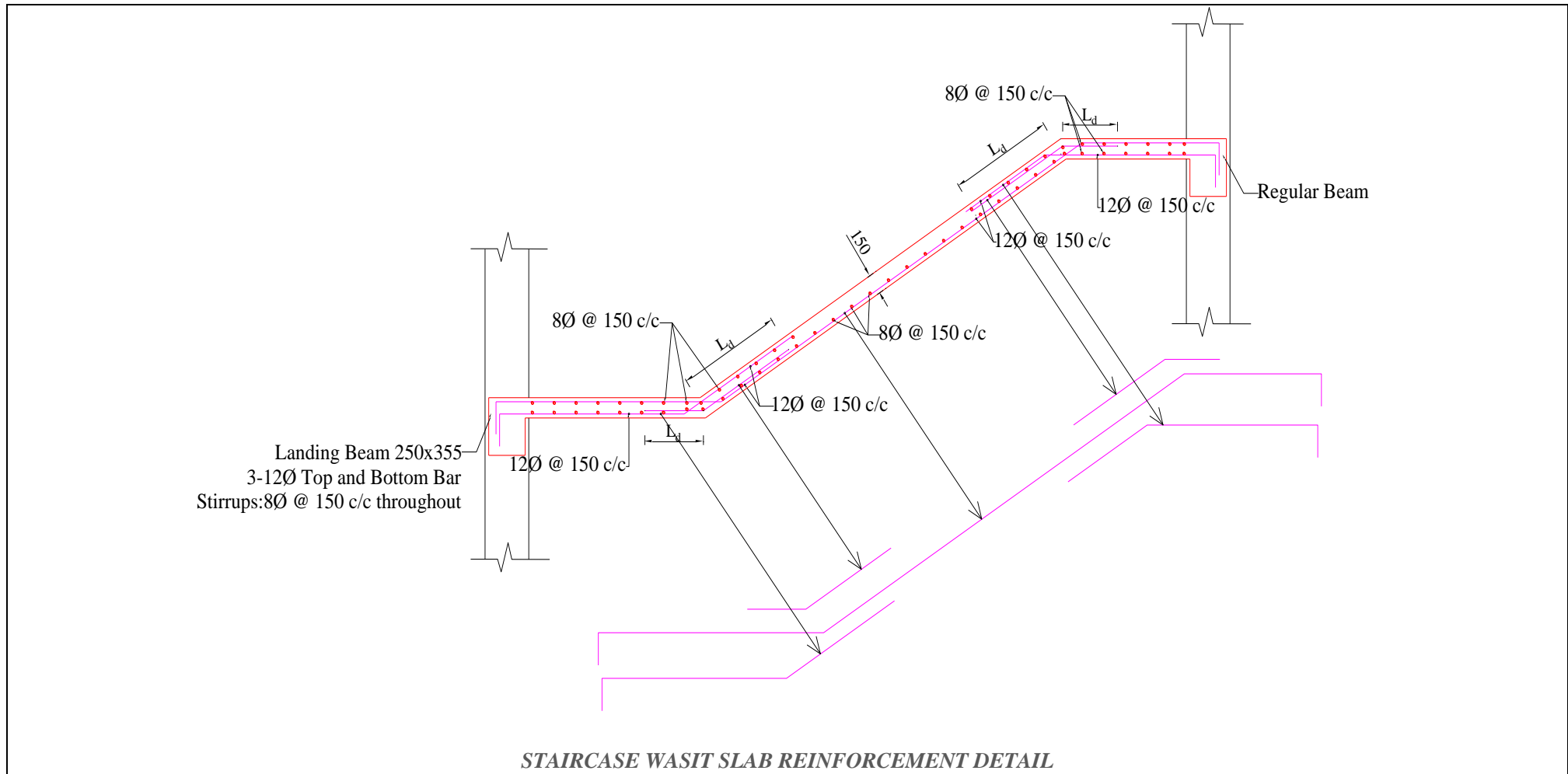
FIGURE 10-4 STAIRCASE LANDING BEAM ARRANGEMENT AND REINFORCEMENT DETAIL

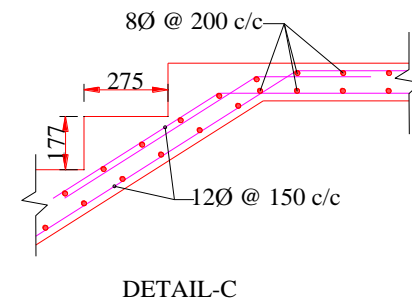
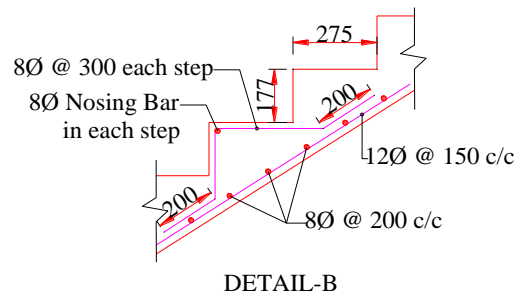
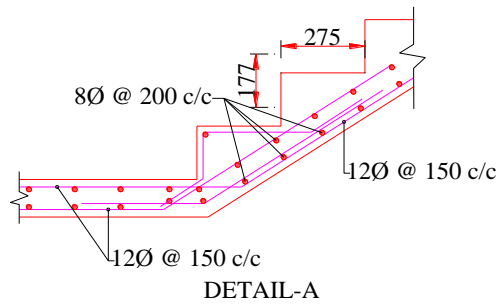
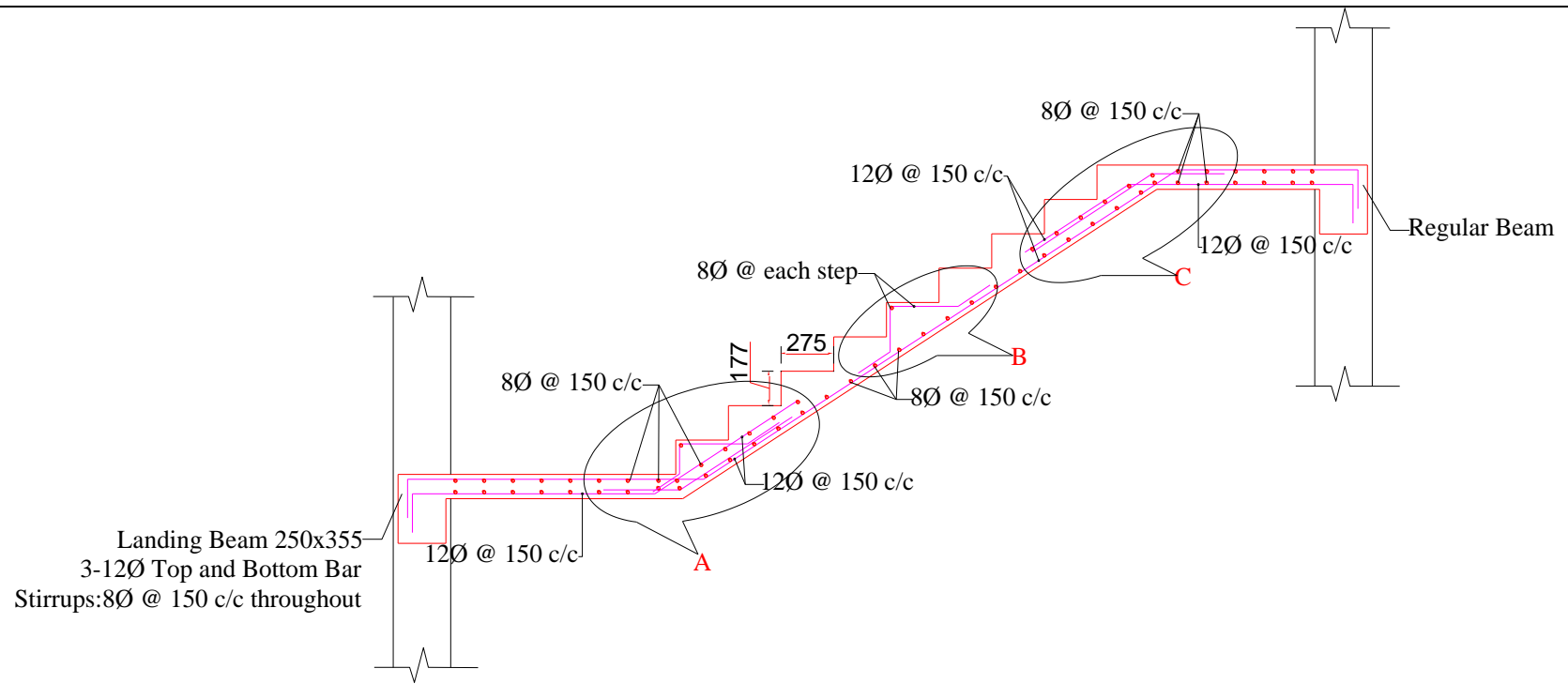


1. Staircase incline slab depth = 150 mm
2. Trade and riser size: As per building plan
3. Width of the staircase flight: 1050 mm

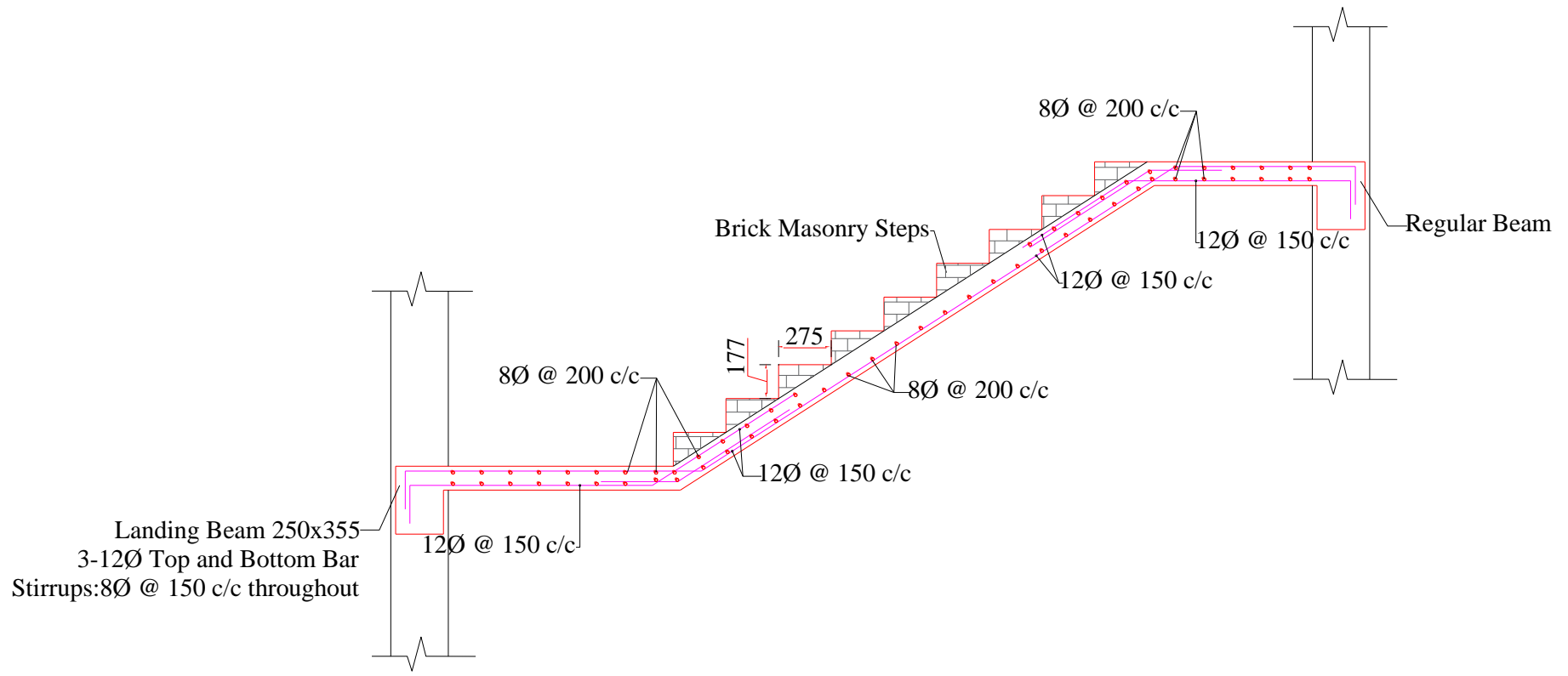
Note: Landing beam shall be supported on wall only. Nearby columns should not be used to support the landing beam.

FIGURE 10-5 STAIRCASE DETAIL (OPTION I- WITH RCC STEPS) & (OPTION II- WITH MASORNY STEPS)





STAIRCASE REINFORCEMENT DETAIL (OPTION I- RCC WASIT SLAB WITH RCC STEPS)



STAIRCASE REINFORCEMENT DETAIL (OPTION II- RCC WASIT SLAB WITH MASONRY STEPS)

11. Reinforcing Non-Load Bearing Walls

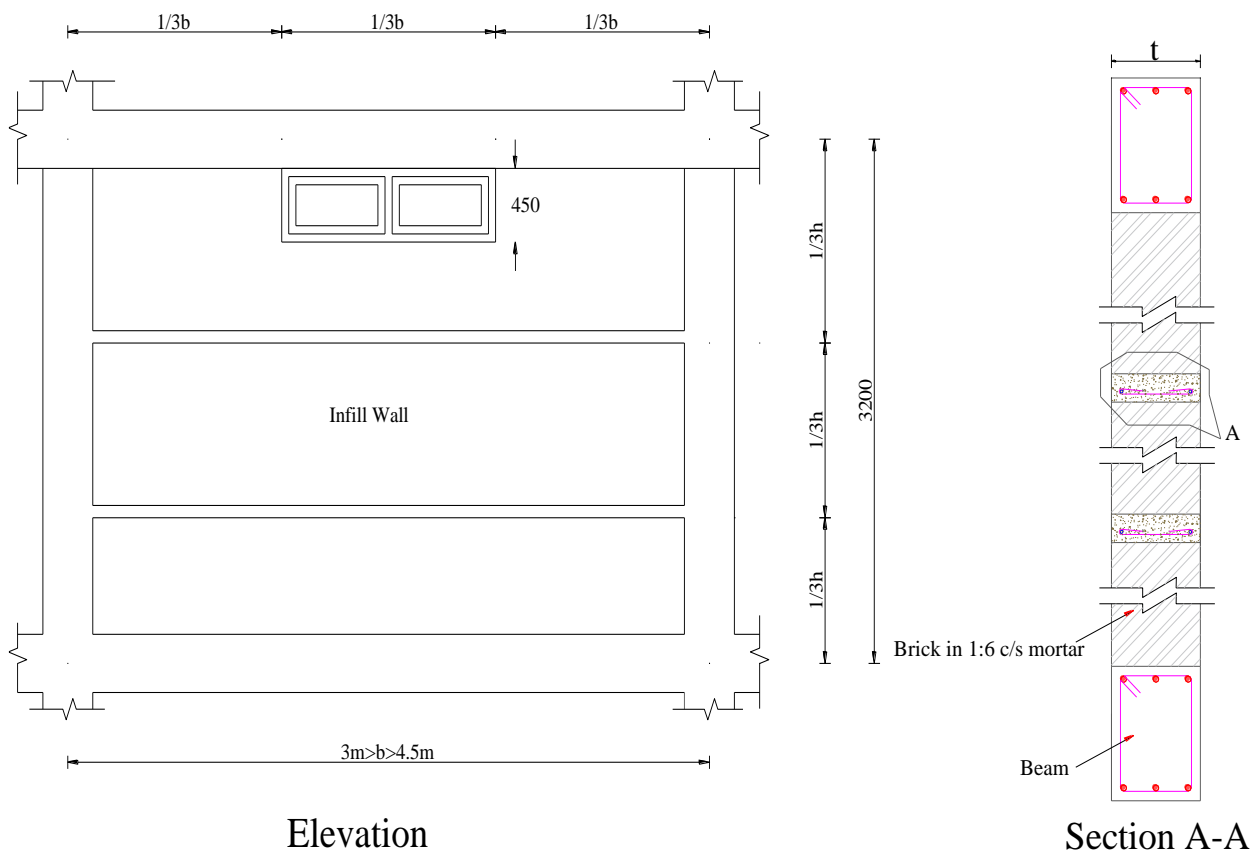
11.1 Between Framing Columns

11.1.1 Solid Walls

To prevent walls from falling out, these shall be provided with horizontal reinforced concrete (RC) bands through the wall at about one-third and two-thirds of their height above the floor in each storey. The width of the band should be equal to the wall thickness and its thickness equal to that of the masonry unit, or 75 mm, whichever is larger. Reinforcement details shall be as given in **Figure 11-1**.

Reinforcement:

- a) Longitudinal - Two bars 10 mm ϕ (Fe500) anchored in the RC column abutting the wall.
- b) Transverse - links 8mm ϕ (Fe 500) at every 150 mm.



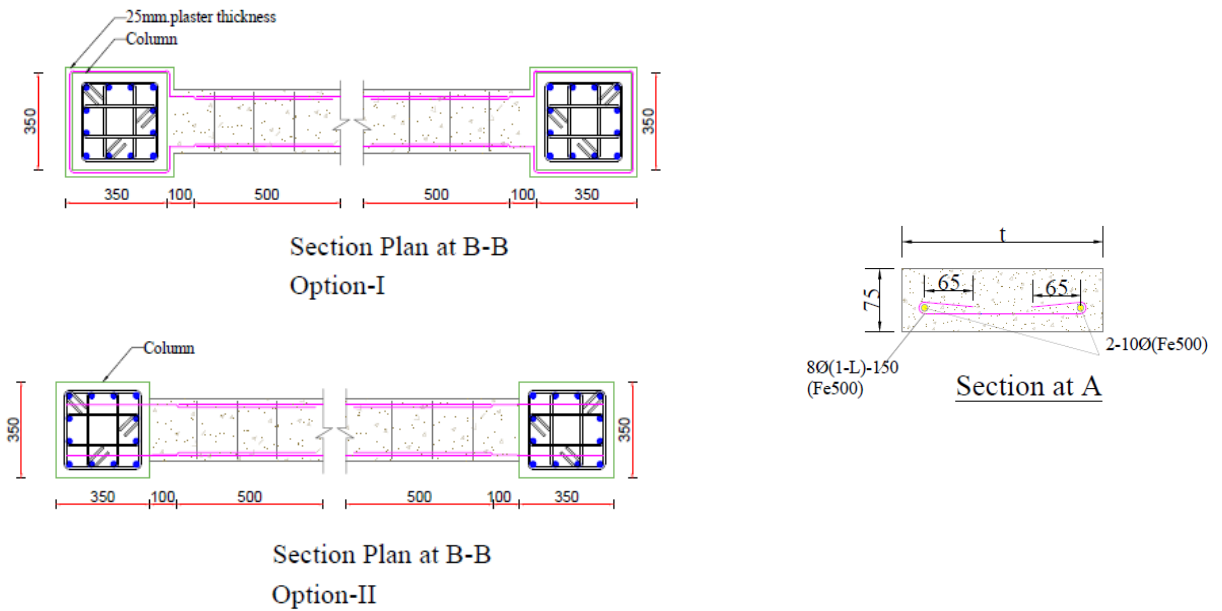
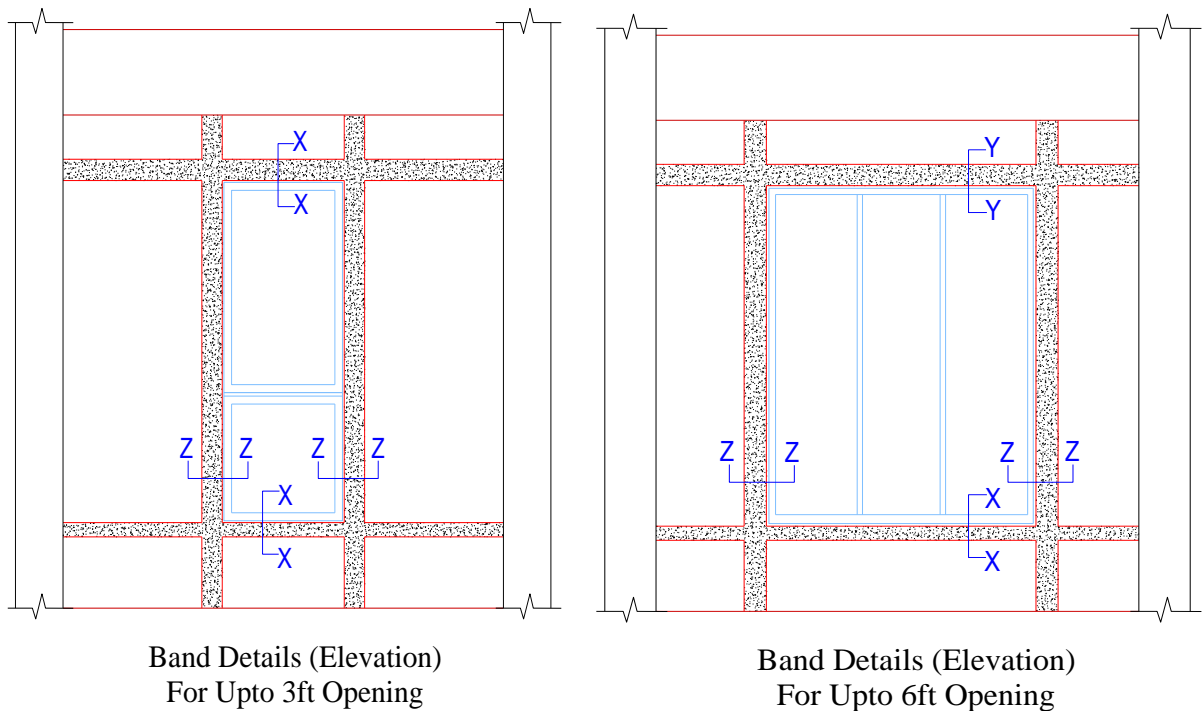
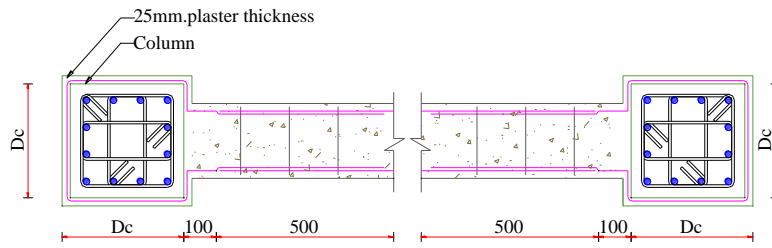
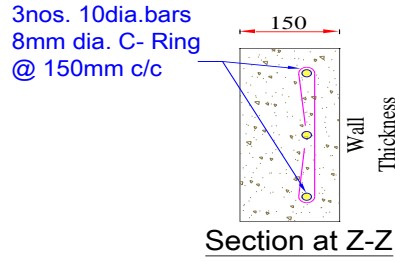
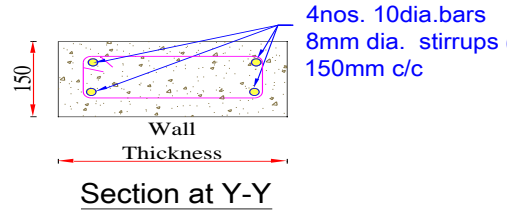
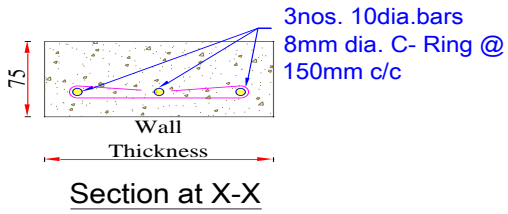


FIGURE 11-1 REINFORCEMENT DETAILS FOR SOLID WALL

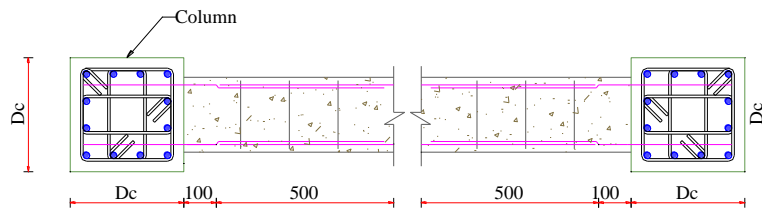
11.2 Walls with Openings

A horizontal RC band shall be provided through the wall at the lintel level of doors and windows and at window sill level in each storey as given in **Cl 11.1.1**. Details of the arrangement shall be as given in **Figure 11-2**.





Section Plan at B-B
Option-I



Section Plan at B-B
Option-II

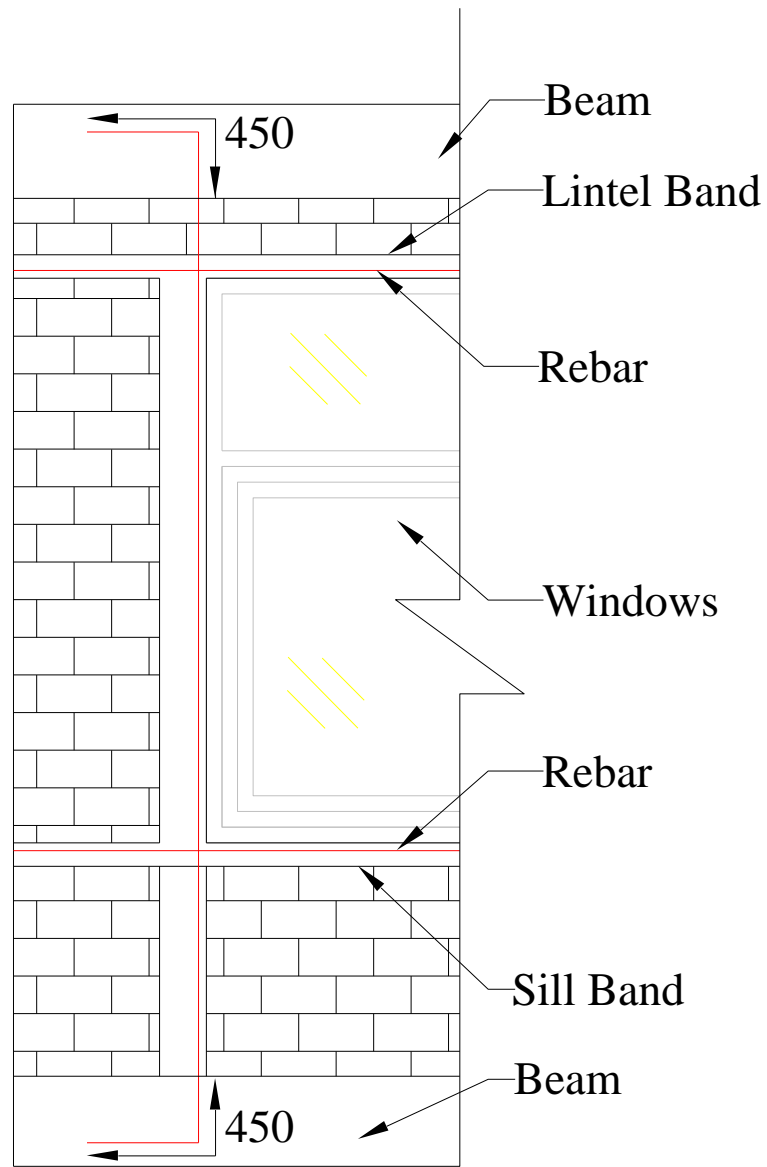


FIGURE 11-2 BAND DETAILS FOR SOLID WALL WITH OPENING

12. Parapets

12.1 General

Parapets above roofs and at the edges of the balconies should not be taller than 1 m. They should either be constructed in reinforced concrete or be reinforced with vertical RC elements spaced not more than 1.5 m apart. The section of the vertical RC post may be kept to $b \times 75$ mm, where b is the thickness of the parapet. Such RC elements should be reinforced with two vertical bars of 8 mm diameter steel (Fe500 or Fe415) with transverse links 4.75 mm ϕ diameter steel (Fe 500 or Fe 415) @ 150 mm centres. The vertical reinforcement shall be tied in the steel of the slab or beam below with a minimum embedment of 300 mm. Also, a handrail should be provided at the top with a section size and reinforcing as explained in **CI 11.1.1**. For details, **Figure 12-1** shall be referred.

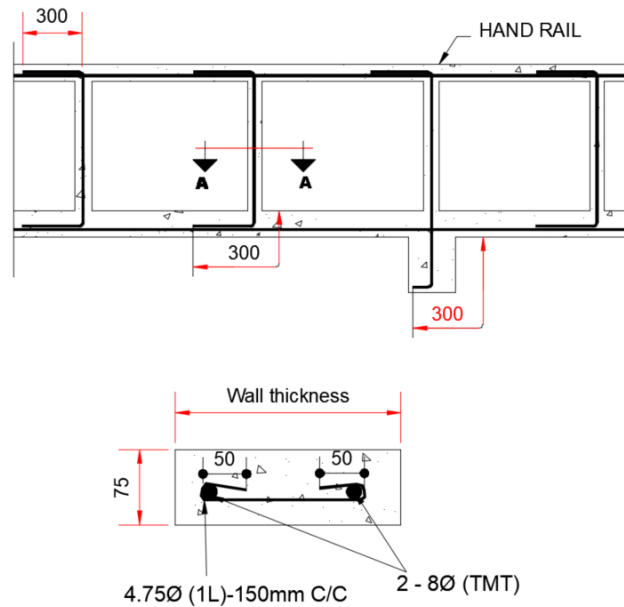


FIGURE 12-1 REINFORCING DETAIL OF PARAPETS

12.2 Flower Pots

Flower pots should not normally be placed on parapets. However, if it is desired that they be placed there, they shall be adequately wired and held to the parapet through pre-fixed steel hooks/anchors so that they will not be dislodged in severe earthquake shaking.

ANNEX

SN	District	Local Units	PGA	SN	District	Local Units	PGA
1	Achham	Bannigadhi Jayagadh Gaunpalika	0.35	38	Bajhang	Bungal Nagarpalika	0.35
2	Achham	Chaurpati Gaunpalika	0.35	39	Bajhang	Chabispathivera Gaunpalika	0.35
3	Achham	Dhakari Gaunpalika	0.35	40	Bajhang	Durgathali Gaunpalika	0.35
4	Achham	Kamalbazar Nagarpalika	0.35	41	Bajhang	JayaPrithivi Nagarpalika	0.35
5	Achham	Mangalsen Nagarpalika	0.35	42	Bajhang	Kanda Gaunpalika	0.3
6	Achham	Mellekh Gaunpalika	0.35	43	Bajhang	Kedarseu Gaunpalika	0.35
7	Achham	Panchadewal Binayak Nagarpalika	0.35	44	Bajhang	Khaptadchhanna Gaunpalika	0.35
8	Achham	Ramaroshan Gaunpalika	0.35	45	Bajhang	Masta Gaunpalika	0.35
9	Achham	Sanphebagar Nagarpalika	0.35	46	Bajhang	Surma Gaunpalika	0.35
10	Achham	Turmakhad Gaunpalika	0.35	47	Bajhang	Talkot Gaunpalika	0.3
11	Arghakhanchi	Bhumekasthan Nagarpalika	0.35	48	Bajhang	Thalara Gaunpalika	0.35
12	Arghakhanchi	Chhatradev Gaunpalika	0.35	49	Bajura	Badimalika Nagarpalika	0.35
13	Arghakhanchi	Malarani Gaunpalika	0.35	50	Bajura	Budhiganga Nagarpalika	0.35
14	Arghakhanchi	Panini Gaunpalika	0.35	51	Bajura	Budhinanda Nagarpalika	0.3
15	Arghakhanchi	Sandhikharka Nagarpalika	0.35	52	Bajura	Chhededaha Gaunpalika	0.35
16	Arghakhanchi	Sitganga Nagarpalika	0.4	53	Bajura	Gaumul Gaunpalika	0.35
17	Baglung	Badigad Gaunpalika	0.35	54	Bajura	Himali Gaunpalika	0.3
18	Baglung	Baglung Nagarpalika	0.35	55	Bajura	Pandav Gupha Gaunpalika	0.35
19	Baglung	Bareng Gaunpalika	0.35	56	Bajura	Swami Kartik Gaunpalika	0.3
20	Baglung	Dhorpatan Nagarpalika	0.35	57	Bajura	Tribeni Nagarpalika	0.35
21	Baglung	Galkot Nagarpalika	0.35	58	Banke	Baijanath Gaunpalika	0.4
22	Baglung	Jaimuni Nagarpalika	0.35	59	Banke	Duduwa Gaunpalika	0.4
23	Baglung	Kanthekhola Gaunpalika	0.35	60	Banke	Janki Gaunpalika	0.4
24	Baglung	Nisikhola Gaunpalika	0.35	61	Banke	Khajura Gaunpalika	0.35
25	Baglung	Taman Khola Gaunpalika	0.3	62	Banke	Kohalpur Nagarpalika	0.4
26	Baglung	Tara Khola Gaunpalika	0.35	63	Banke	Narainapur Gaunpalika	0.4
27	Baitadi	Dasharathchanda Nagarpalika	0.35	64	Banke	Nepalgunj Upamahanagarpalika	0.4
28	Baitadi	Dilasaini Gaunpalika	0.35	65	Banke	Rapti Sonari Gaunpalika	0.4
29	Baitadi	Dogadakedar Gaunpalika	0.35	66	Bara	Adarshkotwal Gaunpalika	0.35
30	Baitadi	Melauli Nagarpalika	0.35	67	Bara	Baragadhi Gaunpalika	0.35
31	Baitadi	Pancheshwar Gaunpalika	0.35	68	Bara	Bishrampur Gaunpalika	0.35
32	Baitadi	Patan Nagarpalika	0.35	69	Bara	Devtal Gaunpalika	0.35
33	Baitadi	Purchaudi Nagarpalika	0.35	70	Bara	Jitpur Simara Upamahanagarpalika	0.35
34	Baitadi	Shivanath Gaunpalika	0.35	71	Bara	Kalaiya Upamahanagarpalika	0.35
35	Baitadi	Sigas Gaunpalika	0.35	72	Bara	Karaiyamai Gaunpalika	0.35
36	Baitadi	Surnaya Gaunpalika	0.35	73	Bara	Kolhabi Nagarpalika	0.35
37	Bajhang	Bithadchir Gaunpalika	0.35	74	Bara	Mahagadhimai Nagarpalika	0.35

SN	District	Local Units	PGA	SN	District	Local Units	PGA
75	Bara	Nijgadh Nagarpalika	0.35	111	Dadeldhura	Alital Gaunpalika	0.35
76	Bara	Pacharauta Nagarpalika	0.3	112	Dadeldhura	Amargadhi Nagarpalika	0.35
77	Bara	Parwanipur Gaunpalika	0.35	113	Dadeldhura	Bhageshwar Gaunpalika	0.35
78	Bara	Pheta Gaunpalika	0.35	114	Dadeldhura	Ganayapdhura Gaunpalika	0.35
79	Bara	Prasauni Gaunpalika	0.35	115	Dadeldhura	Nawadurga Gaunpalika	0.35
80	Bara	Simraungadh Nagarpalika	0.3	116	Dadeldhura	Parashuram Nagarpalika	0.35
81	Bara	Suwarna Gaunpalika	0.35	117	Dailekh	Aathabis Nagarpalika	0.35
82	Bardiya	Badhaiyatal Gaunpalika	0.35	118	Dailekh	Bhagawatimai Gaunpalika	0.35
83	Bardiya	Bansagadhi Nagarpalika	0.4	119	Dailekh	Bhairabi Gaunpalika	0.35
84	Bardiya	Barbardiya Nagarpalika	0.35	120	Dailekh	Chamunda Bindrasaini Nagarpalika	0.35
85	Bardiya	Geruwa Gaunpalika	0.35	121	Dailekh	Dullu Nagarpalika	0.35
86	Bardiya	Gulariya Nagarpalika	0.4	122	Dailekh	Dungeshwor Gaunpalika	0.35
87	Bardiya	Madhuwan Nagarpalika	0.35	123	Dailekh	Gurans Gaunpalika	0.35
88	Bardiya	Rajapur Nagarpalika	0.35	124	Dailekh	Mahabu Gaunpalika	0.35
89	Bardiya	Thakurbaba Nagarpalika	0.35	125	Dailekh	Narayan Nagarpalika	0.35
90	Bhaktapur	Bhaktapur Nagarpalika	0.35	126	Dailekh	Naumule Gaunpalika	0.35
91	Bhaktapur	Changunarayan Nagarpalika	0.35	127	Dailekh	Thantikandh Gaunpalika	0.35
92	Bhaktapur	Madhyapur Thimi Nagarpalika	0.35	128	Dang	Babai Gaunpalika	0.4
93	Bhaktapur	Suryabinayak Nagarpalika	0.35	129	Dang	Banglachuli Gaunpalika	0.4
94	Bhojpur	Aamchowk Gaunpalika	0.4	130	Dang	Dangisharan Gaunpalika	0.4
95	Bhojpur	Arun Gaunpalika	0.35	131	Dang	Gadhawa Gaunpalika	0.4
96	Bhojpur	Bhojpur Nagarpalika	0.35	132	Dang	Ghorahi Upamahanagarpalika	0.4
97	Bhojpur	Hatuwadadhi Gaunpalika	0.4	133	Dang	Lamahi Nagarpalika	0.4
98	Bhojpur	Pauwadungma Gaunpalika	0.35	134	Dang	Rajpur Gaunpalika	0.4
99	Bhojpur	Ramprasad Rai Gaunpalika	0.35	135	Dang	Rapti Gaunpalika	0.4
100	Bhojpur	Salpasilichho Gaunpalika	0.35	136	Dang	Shantinagar Gaunpalika	0.4
101	Bhojpur	Shadananda Nagarpalika	0.35	137	Dang	Tulsipur Upamahanagarpalika	0.4
102	Bhojpur	Tyamkemaityung Gaunpalika	0.35	138	Darchula	Apihimal Gaunpalika	0.3
103	Chitawan	Bharatpur Mahanagarpalika	0.4	139	Darchula	Byas Gaunpalika	0.3
104	Chitawan	Ichchhyakamana Gaunpalika	0.35	140	Darchula	Dunhu Gaunpalika	0.3
105	Chitawan	Kalika Nagarpalika	0.35	141	Darchula	Lekam Gaunpalika	0.35
106	Chitawan	Khairahani Nagarpalika	0.4	142	Darchula	Mahakali Nagarpalika	0.35
107	Chitawan	Madi Nagarpalika	0.4	143	Darchula	Malikaarjun Gaunpalika	0.35
108	Chitawan	Rapti Nagarpalika	0.35	144	Darchula	Marma Gaunpalika	0.35
109	Chitawan	Ratnanagar Nagarpalika	0.4	145	Darchula	Naugad Gaunpalika	0.35
110	Dadeldhura	Ajaymeru Gaunpalika	0.35	146	Darchula	Shailyashikhar Nagarpalika	0.35
147	Dhading	Benighat Rorang Gaunpalika	0.35	148	Dhading	Dhunibesi Nagarpalika	0.35

SN	District	Local Units	PGA	SN	District	Local Units	PGA
149	Dhading	Gajuri Gaunpalika	0.35	186	Dolakha	Bhimeshwor Nagarpalika	0.3
150	Dhading	Galchi Gaunpalika	0.35	187	Dolakha	Bigu Gaunpalika	0.3
151	Dhading	Gangajamuna Gaunpalika	0.3	188	Dolakha	Gaurishankar Gaunpalika	0.3
152	Dhading	Jwalamukhi Gaunpalika	0.35	189	Dolakha	Jiri Nagarpalika	0.3
153	Dhading	Khaniyabash Gaunpalika	0.3	190	Dolakha	Kalinchok Gaunpalika	0.3
154	Dhading	Netrawati Dabjong Gaunpalika	0.35	191	Dolakha	Melung Gaunpalika	0.35
155	Dhading	Nilakantha Nagarpalika	0.35	192	Dolakha	Sailung Gaunpalika	0.35
156	Dhading	Rubi Valley Gaunpalika	0.3	193	Dolakha	Tamakoshi Gaunpalika	0.35
157	Dhading	Siddhalek Gaunpalika	0.35	194	Dolpa	Chharka Tangsong Gaunpalika	0.3
158	Dhading	Thakre Gaunpalika	0.35	195	Dolpa	Dolpo Buddha Gaunpalika	0.25
159	Dhading	Tripura Sundari Gaunpalika	0.35	196	Dolpa	Jagadulla Gaunpalika	0.3
160	Dhankuta	Chaubise Gaunpalika	0.35	197	Dolpa	Kaike Gaunpalika	0.3
161	Dhankuta	Chhathar Jorpati Gaunpalika	0.35	198	Dolpa	Mudkechula Gaunpalika	0.3
162	Dhankuta	Dhankuta Nagarpalika	0.4	199	Dolpa	Shey Phoksundo Gaunpalika	0.25
163	Dhankuta	Mahalaxmi Nagarpalika	0.35	200	Dolpa	Thuli Bheri Nagarpalika	0.3
164	Dhankuta	Pakhribas Nagarpalika	0.35	201	Dolpa	Tripurasundari Nagarpalika	0.3
165	Dhankuta	Sangurigadhi Gaunpalika	0.4	202	Doti	Adharsha Gaunpalika	0.35
166	Dhankuta	Shahidbhumi Gaunpalika	0.4	203	Doti	Badikedar Gaunpalika	0.35
167	Dhanusha	Aaurahi Gaunpalika	0.35	204	Doti	Bogtan Gaunpalika	0.35
168	Dhanusha	Bateshwor Gaunpalika	0.35	205	Doti	Dipayal Silgadi Nagarpalika	0.35
169	Dhanusha	Bideha Nagarpalika	0.35	206	Doti	Joroyal Gaunpalika	0.35
170	Dhanusha	Chhireswornath Nagarpalika	0.35	207	Doti	K I Singh Gaunpalika	0.35
171	Dhanusha	Dhanauji Gaunpalika	0.35	208	Doti	Purbichauki Gaunpalika	0.35
172	Dhanusha	Dhanusadham Nagarpalika	0.35	209	Doti	Sayal Gaunpalika	0.35
173	Dhanusha	Ganeshman Charnath Nagarpalika	0.35	210	Doti	Shikhar Nagarpalika	0.35
174	Dhanusha	Hansapur Nagarpalika	0.35	211	Gorkha	Aarughat Gaunpalika	0.3
175	Dhanusha	Janaknandani Gaunpalika	0.35	212	Gorkha	Ajirkot Gaunpalika	0.3
176	Dhanusha	Janakpur Upamahanagarpalika	0.35	213	Gorkha	Bhimsen Gaunpalika	0.35
177	Dhanusha	Kamala Nagarpalika	0.35	214	Gorkha	Chum Nubri Gaunpalika	0.3
178	Dhanusha	Lakshminiya Gaunpalika	0.35	215	Gorkha	Dharche Gaunpalika	0.3
179	Dhanusha	Mithila Bihari Nagarpalika	0.35	216	Gorkha	Gandaki Gaunpalika	0.35
180	Dhanusha	Mithila Nagarpalika	0.35	217	Gorkha	Gorkha Nagarpalika	0.35
181	Dhanusha	Mukhiyapatti Musarmiya Gaunpalika	0.3	218	Gorkha	Palungtar Nagarpalika	0.35
182	Dhanusha	Nagarain Nagarpalika	0.3	219	Gorkha	Sahid Lakhani Gaunpalika	0.35
183	Dhanusha	Sabaila Nagarpalika	0.35	220	Gorkha	Siranchok Gaunpalika	0.3
184	Dhanusha	Sahidnagar Nagarpalika	0.35	221	Gorkha	Sulikot Gaunpalika	0.3
185	Dolakha	Baiteshwor Gaunpalika	0.3	222	Gulmi	Chandrakot Gaunpalika	0.35

SN	District	Local Units	PGA	SN	District	Local Units	PGA
223	Gulmi	Chatrakot Gaunpalika	0.35	260	Jhapa	Bhadrapur Nagarpalika	0.35
224	Gulmi	Dhurkot Gaunpalika	0.35	261	Jhapa	Birtamod Nagarpalika	0.35
225	Gulmi	Gulmidarbar Gaunpalika	0.35	262	Jhapa	Buddhashanti Gaunpalika	0.35
226	Gulmi	Isma Gaunpalika	0.35	263	Jhapa	Damak Nagarpalika	0.35
227	Gulmi	Kaligandaki Gaunpalika	0.35	264	Jhapa	Gauradhaha Nagarpalika	0.35
228	Gulmi	Madane Gaunpalika	0.35	265	Jhapa	Gauriganj Gaunpalika	0.3
229	Gulmi	Malika Gaunpalika	0.35	266	Jhapa	Haldibari Gaunpalika	0.35
230	Gulmi	Musikot Nagarpalika	0.35	267	Jhapa	Jhapa Gaunpalika	0.3
231	Gulmi	Resunga Nagarpalika	0.35	268	Jhapa	Kachankawal Gaunpalika	0.3
232	Gulmi	Ruru Gaunpalika	0.35	269	Jhapa	Kamal Gaunpalika	0.35
233	Gulmi	Satyawati Gaunpalika	0.35	270	Jhapa	Kankai Nagarpalika	0.35
234	Humla	Adanchuli Gaunpalika	0.3	271	Jhapa	Mechinagar Nagarpalika	0.35
235	Humla	Chankheli Gaunpalika	0.3	272	Jhapa	Shivasataxi Nagarpalika	0.35
236	Humla	Kharpunath Gaunpalika	0.3	273	Jumla	Chandannath Nagarpalika	0.3
237	Humla	Namkha Gaunpalika	0.3	274	Jumla	Guthichaur Gaunpalika	0.3
238	Humla	Sarkegad Gaunpalika	0.3	275	Jumla	Hima Gaunpalika	0.3
239	Humla	Simkot Gaunpalika	0.3	276	Jumla	Kanakasundari Gaunpalika	0.3
240	Humla	Tanjakot Gaunpalika	0.3	277	Jumla	Patrasi Gaunpalika	0.3
241	Illam	Chulachuli Gaunpalika	0.35	278	Jumla	Sinja Gaunpalika	0.3
242	Illam	Deumai Nagarpalika	0.4	279	Jumla	Tatopani Gaunpalika	0.3
243	Illam	Fakphokthum Gaunpalika	0.35	280	Jumla	Tila Gaunpalika	0.35
244	Illam	Illam Nagarpalika	0.4	281	Kabhrepalanchok	Banepa Nagarpalika	0.35
245	Illam	Mai Nagarpalika	0.35	282	Kabhrepalanchok	Bethanchowk Gaunpalika	0.35
246	Illam	Maijogmai Gaunpalika	0.4	283	Kabhrepalanchok	Bhumlu Gaunpalika	0.35
247	Illam	Mangsebung Gaunpalika	0.4	284	Kabhrepalanchok	Chaurideurali Gaunpalika	0.35
248	Illam	Rong Gaunpalika	0.35	285	Kabhrepalanchok	Dhulikhel Nagarpalika	0.35
249	Illam	Sandakpur Gaunpalika	0.35	286	Kabhrepalanchok	Khanikhola Gaunpalika	0.35
250	Illam	Suryodaya Nagarpalika	0.35	287	Kabhrepalanchok	Mahabharat Gaunpalika	0.35
251	Jajarkot	Barekot Gaunpalika	0.3	288	Kabhrepalanchok	Mandandeupur Nagarpalika	0.35
252	Jajarkot	Bheri Nagarpalika	0.35	289	Kabhrepalanchok	Namobuddha Nagarpalika	0.35
253	Jajarkot	Chhedagad Nagarpalika	0.35	290	Kabhrepalanchok	Panauti Nagarpalika	0.35
254	Jajarkot	Junichande Gaunpalika	0.35	291	Kabhrepalanchok	Panchkhal Nagarpalika	0.35
255	Jajarkot	Kuse Gaunpalika	0.35	292	Kabhrepalanchok	Roshi Gaunpalika	0.35
256	Jajarkot	Shiwalaya Gaunpalika	0.35	293	Kabhrepalanchok	Temal Gaunpalika	0.35
257	Jajarkot	Tribeni Nalagad Nagarpalika	0.3	294	Kailali	Bardagoriya Gaunpalika	0.35
258	Jhapa	Arjundhara Nagarpalika	0.35	295	Kailali	Bhajani Nagarpalika	0.35
259	Jhapa	Barhadashi Gaunpalika	0.35	296	Kailali	Chure Gaunpalika	0.35

SN	District	Local Units	PGA	SN	District	Local Units	PGA
297	Kailali	Dhangadhi Upamahanagarpalika	0.4	334	Kapilbastu	Yashodhara Gaunpalika	0.35
298	Kailali	Gauriganga Nagarpalika	0.35	335	Kaski	Annapurna Gaunpalika	0.3
299	Kailali	Ghodaghodi Nagarpalika	0.35	336	Kaski	Machhapuchchhre Gaunpalika	0.3
300	Kailali	Godawari Nagarpalika	0.35	337	Kaski	Madi Gaunpalika	0.3
301	Kailali	Janaki Gaunpalika	0.35	338	Kaski	Pokhara Lekhnath Mahanagarpalika	0.35
302	Kailali	Joshiपुर Gaunpalika	0.35	339	Kaski	Rupa Gaunpalika	0.35
303	Kailali	Kailari Gaunpalika	0.3	340	Kathmandu	Budhanilakantha Nagarpalika	0.35
304	Kailali	Lamkichuha Nagarpalika	0.35	341	Kathmandu	Chandragiri Nagarpalika	0.35
305	Kailali	Mohanyal Gaunpalika	0.35	342	Kathmandu	Dakshinkali Nagarpalika	0.35
306	Kailali	Tikapur Nagarpalika	0.35	343	Kathmandu	Gokarneshwor Nagarpalika	0.35
307	Kalikot	Kalika Gaunpalika	0.35	344	Kathmandu	Kageshwori Manahora Nagarpalika	0.35
308	Kalikot	Khandachakra Nagarpalika	0.35	345	Kathmandu	Kathmandu Mahanagarpalika	0.35
309	Kalikot	Mahawai Gaunpalika	0.35	346	Kathmandu	Kirtipur Nagarpalika	0.35
310	Kalikot	Naraharinath Gaunpalika	0.35	347	Kathmandu	Nagarjun Nagarpalika	0.35
311	Kalikot	Pachaljharana Gaunpalika	0.35	348	Kathmandu	Shankharapur Nagarpalika	0.35
312	Kalikot	Palata Gaunpalika	0.35	349	Kathmandu	Tarakeshwor Nagarpalika	0.35
313	Kalikot	Raskot Nagarpalika	0.35	350	Kathmandu	Tokha Nagarpalika	0.35
314	Kalikot	Sanni Tribeni Gaunpalika	0.35	351	Khotang	Ainselukhark Gaunpalika	0.35
315	Kalikot	Tilagufa Nagarpalika	0.35	352	Khotang	Barahapokhari Gaunpalika	0.4
316	Kanchanpur	Bedkot Nagarpalika	0.35	353	Khotang	Diprung Gaunpalika	0.35
317	Kanchanpur	Belauri Nagarpalika	0.3	354	Khotang	Halesi Tuwachung Nagarpalika	0.35
318	Kanchanpur	Beldandi Gaunpalika	0.35	355	Khotang	Jantedhunga Gaunpalika	0.4
319	Kanchanpur	Bhimdatta Nagarpalika	0.35	356	Khotang	Kepilasagadhi Gaunpalika	0.35
320	Kanchanpur	Krishnapur Nagarpalika	0.35	357	Khotang	Khotehang Gaunpalika	0.4
321	Kanchanpur	Laljhadhi Gaunpalika	0.3	358	Khotang	Rawa Besi Gaunpalika	0.35
322	Kanchanpur	Mahakali Nagarpalika	0.35	359	Khotang	Rupakot Majhuwagadhi Nagarpalika	0.35
323	Kanchanpur	Punarbasi Nagarpalika	0.3	360	Khotang	Sakela Gaunpalika	0.35
324	Kanchanpur	Shuklaphanta Nagarpalika	0.35	361	Lalitpur	Bagmati Gaunpalika	0.35
325	Kapilbastu	Banganga Nagarpalika	0.35	362	Lalitpur	Godawari Nagarpalika	0.35
326	Kapilbastu	Bijayanagar Gaunpalika	0.4	363	Lalitpur	Konjyosom Gaunpalika	0.35
327	Kapilbastu	Buddhabhumi Nagarpalika	0.4	364	Lalitpur	Lalitpur Mahanagarpalika	0.35
328	Kapilbastu	Kapilbastu Nagarpalika	0.35	365	Lalitpur	Mahalaxmi Nagarpalika	0.35
329	Kapilbastu	Krishnanagar Nagarpalika	0.35	366	Lalitpur	Mahankal Gaunpalika	0.35
330	Kapilbastu	Maharajgunj Nagarpalika	0.35	367	Lamjung	Besishahar Nagarpalika	0.3
331	Kapilbastu	Mayadevi Gaunpalika	0.35	368	Lamjung	Dordi Gaunpalika	0.3
332	Kapilbastu	Shivaraj Nagarpalika	0.4	369	Lamjung	Dudhpokhari Gaunpalika	0.3
333	Kapilbastu	Suddhodhan Gaunpalika	0.35	370	Lamjung	Kwholasothar Gaunpalika	0.3

SN	District	Local Units	PGA	SN	District	Local Units	PGA
371	Lamjung	MadhyaNepal Nagarpalika	0.3	408	Morang	Gramthan Gaunpalika	0.35
372	Lamjung	Marsyangdi Gaunpalika	0.3	409	Morang	Jahada Gaunpalika	0.3
373	Lamjung	Rainas Nagarpalika	0.3	410	Morang	Kanepokhari Gaunpalika	0.35
374	Lamjung	Sundarbazar Nagarpalika	0.3	411	Morang	Katahari Gaunpalika	0.35
375	Mahottari	Aurahi Nagarpalika	0.35	412	Morang	Kerabari Gaunpalika	0.35
376	Mahottari	Balwa Nagarpalika	0.35	413	Morang	Letang Nagarpalika	0.35
377	Mahottari	Bardibas Nagarpalika	0.35	414	Morang	Miklajung Gaunpalika	0.35
378	Mahottari	Bhangaha Nagarpalika	0.35	415	Morang	Patahrishanishchare Nagarpalika	0.35
379	Mahottari	Ekdanra Gaunpalika	0.3	416	Morang	Rangeli Nagarpalika	0.3
380	Mahottari	Gaushala Nagarpalika	0.35	417	Morang	Ratuwamai Nagarpalika	0.3
381	Mahottari	Jaleswor Nagarpalika	0.3	418	Morang	Sundarharaicha Nagarpalika	0.35
382	Mahottari	Loharpatti Nagarpalika	0.35	419	Morang	Sunwarshi Nagarpalika	0.3
383	Mahottari	Mahottari Gaunpalika	0.3	420	Morang	Uralabari Nagarpalika	0.35
384	Mahottari	Manra Siswa Nagarpalika	0.3	421	Mugu	Chhayanath Rara Nagarpalika	0.3
385	Mahottari	Matihani Nagarpalika	0.3	422	Mugu	Khatyad Gaunpalika	0.3
386	Mahottari	Pipra Gaunpalika	0.35	423	Mugu	Mugum Karmarong Gaunpalika	0.3
387	Mahottari	Ramgopalpur Nagarpalika	0.35	424	Mugu	Soru Gaunpalika	0.3
388	Mahottari	Samsi Gaunpalika	0.35	425	Mustang	Barhagaun Muktiikhsetra Gaunpalika	0.3
389	Mahottari	Sonama Gaunpalika	0.35	426	Mustang	Dalome Gaunpalika	0.3
390	Makwanpur	Bagmati Gaunpalika	0.35	427	Mustang	Gharapjhong Gaunpalika	0.3
391	Makwanpur	Bakaiya Gaunpalika	0.35	428	Mustang	Lomanthang Gaunpalika	0.3
392	Makwanpur	Bhimphedi Gaunpalika	0.35	429	Mustang	Thasang Gaunpalika	0.3
393	Makwanpur	Hetauda Upamahanagarpalika	0.4	430	Myagdi	Annapurna Gaunpalika	0.3
394	Makwanpur	Indrasarowar Gaunpalika	0.35	431	Myagdi	Beni Nagarpalika	0.3
395	Makwanpur	Kailash Gaunpalika	0.35	432	Myagdi	Dhaulagiri Gaunpalika	0.3
396	Makwanpur	Makawanpurgadhi Gaunpalika	0.35	433	Myagdi	Malika Gaunpalika	0.3
397	Makwanpur	Manahari Gaunpalika	0.35	434	Myagdi	Mangala Gaunpalika	0.3
398	Makwanpur	Raksirang Gaunpalika	0.35	435	Myagdi	Raghuganga Gaunpalika	0.3
399	Makwanpur	Thaha Nagarpalika	0.35	436	Nawalparasi_E	Binayee Tribeni Gaunpalika	0.35
400	Manang	Chame Gaunpalika	0.3	437	Nawalparasi_E	Bulingtar Gaunpalika	0.35
401	Manang	Narphu Gaunpalika	0.3	438	Nawalparasi_E	Bungdikali Gaunpalika	0.35
402	Manang	Nashong Gaunpalika	0.3	439	Nawalparasi_E	Devchuli Nagarpalika	0.35
403	Manang	Neshyang Gaunpalika	0.3	440	Nawalparasi_E	Gaidakot Nagarpalika	0.35
404	Morang	Belbari Nagarpalika	0.35	441	Nawalparasi_E	Hupsekot Gaunpalika	0.35
405	Morang	Biratnagar Mahanagarpalika	0.35	442	Nawalparasi_E	Kawasoti Nagarpalika	0.4
406	Morang	Budhiganga Gaunpalika	0.35	443	Nawalparasi_E	Madhyabindu Nagarpalika	0.4
407	Morang	Dhanpalthan Gaunpalika	0.3	444	Nawalparasi_W	Bardaghat Nagarpalika	0.35

SN	District	Local Units	PGA	SN	District	Local Units	PGA
445	Nawalparasi_W	Palhi Nandan Gaunpalika	0.35	482	Panchthar	Falgunanda Gaunpalika	0.35
446	Nawalparasi_W	Pratappur Gaunpalika	0.35	483	Panchthar	Hilihang Gaunpalika	0.35
447	Nawalparasi_W	Ramgram Nagarpalika	0.4	484	Panchthar	Kummayak Gaunpalika	0.35
448	Nawalparasi_W	Sarawal Gaunpalika	0.35	485	Panchthar	Miklajung Gaunpalika	0.35
449	Nawalparasi_W	Sunwal Nagarpalika	0.35	486	Panchthar	Phidim Nagarpalika	0.35
450	Nawalparasi_W	TribeniSusta Gaunpalika	0.35	487	Panchthar	Tumbewa Gaunpalika	0.35
451	Nuwakot	Belkotgadhi Nagarpalika	0.35	488	Panchthar	Yangwarak Gaunpalika	0.35
452	Nuwakot	Bidur Nagarpalika	0.35	489	Parbat	Bihadi Gaunpalika	0.35
453	Nuwakot	Dupcheshwar Gaunpalika	0.35	490	Parbat	Jaljala Gaunpalika	0.3
454	Nuwakot	Kakani Gaunpalika	0.35	491	Parbat	Kushma Nagarpalika	0.35
455	Nuwakot	Kispang Gaunpalika	0.3	492	Parbat	Mahashila Gaunpalika	0.35
456	Nuwakot	Likhu Gaunpalika	0.35	493	Parbat	Modi Gaunpalika	0.3
457	Nuwakot	Meghang Gaunpalika	0.35	494	Parbat	Painyu Gaunpalika	0.35
458	Nuwakot	Panchakanya Gaunpalika	0.35	495	Parbat	Phalebas Nagarpalika	0.35
459	Nuwakot	Shivapuri Gaunpalika	0.35	496	Parsa	Bahudaramai Nagarpalika	0.35
460	Nuwakot	Suryagadhi Gaunpalika	0.35	497	Parsa	Bindabasini Gaunpalika	0.35
461	Nuwakot	Tadi Gaunpalika	0.35	498	Parsa	Birgunj Mahanagarpalika	0.35
462	Nuwakot	Tarkeshwar Gaunpalika	0.35	499	Parsa	Chhipaharmai Gaunpalika	0.35
463	Okhaldhunga	Champadevi Gaunpalika	0.35	500	Parsa	Dhobini Gaunpalika	0.35
464	Okhaldhunga	Chisankhugadhi Gaunpalika	0.35	501	Parsa	Jagarnathpur Gaunpalika	0.35
465	Okhaldhunga	Khijidemba Gaunpalika	0.35	502	Parsa	Jirabhawani Gaunpalika	0.35
466	Okhaldhunga	Likhu Gaunpalika	0.35	503	Parsa	Kalikamai Gaunpalika	0.35
467	Okhaldhunga	Manebhanjyang Gaunpalika	0.35	504	Parsa	Pakahamainpur Gaunpalika	0.35
468	Okhaldhunga	Molung Gaunpalika	0.35	505	Parsa	Parsagadhi Nagarpalika	0.35
469	Okhaldhunga	Siddhicharan Nagarpalika	0.35	506	Parsa	Paterwasugauli Gaunpalika	0.35
470	Okhaldhunga	Sunkoshi Gaunpalika	0.35	507	Parsa	Pokhariya Nagarpalika	0.35
471	Palpa	Bagnaskali Gaunpalika	0.35	508	Parsa	SakhuwaPrasauni Gaunpalika	0.35
472	Palpa	Mathagadhi Gaunpalika	0.35	509	Parsa	Thori Gaunpalika	0.4
473	Palpa	Nisdi Gaunpalika	0.35	510	Pyuthan	Ayirabati Gaunpalika	0.35
474	Palpa	Purbakhola Gaunpalika	0.35	511	Pyuthan	Gaumukhi Gaunpalika	0.35
475	Palpa	Rainadevi Chhahara Gaunpalika	0.35	512	Pyuthan	Jhimruk Gaunpalika	0.35
476	Palpa	Rambha Gaunpalika	0.35	513	Pyuthan	Mallarani Gaunpalika	0.35
477	Palpa	Rampur Nagarpalika	0.35	514	Pyuthan	Mandavi Gaunpalika	0.35
478	Palpa	Ribdikot Gaunpalika	0.35	515	Pyuthan	Naubahini Gaunpalika	0.35
479	Palpa	Tansen Nagarpalika	0.35	516	Pyuthan	Pyuthan Nagarpalika	0.35
480	Palpa	Tinau Gaunpalika	0.35	517	Pyuthan	Sarumarani Gaunpalika	0.35
481	Panchthar	Falelung Gaunpalika	0.35	518	Pyuthan	Sworgadwary Nagarpalika	0.35

SN	District	Local Units	PGA	SN	District	Local Units	PGA
519	Ramechhap	Doramba Gaunpalika	0.35	556	Rolpa	Sunchhahari Gaunpalika	0.35
520	Ramechhap	Gokulganga Gaunpalika	0.35	557	Rolpa	Suwarnabati Gaunpalika	0.35
521	Ramechhap	Khadadevi Gaunpalika	0.35	558	Rolpa	Thawang Gaunpalika	0.35
522	Ramechhap	Likhu Tamakoshi Gaunpalika	0.35	559	Rolpa	Tribeni Gaunpalika	0.35
523	Ramechhap	Manthali Nagarpalika	0.35	560	Rukum_E	Bhume Gaunpalika	0.3
524	Ramechhap	Ramechhap Nagarpalika	0.35	561	Rukum_E	Putha Uttarganga Gaunpalika	0.3
525	Ramechhap	Sunapati Gaunpalika	0.35	562	Rukum_E	Sisne Gaunpalika	0.3
526	Ramechhap	Umakunda Gaunpalika	0.3	563	Rukum_W	Aathbiskot Nagarpalika	0.3
527	Rasuwa	Gosaikunda Gaunpalika	0.3	564	Rukum_W	Banfikut Gaunpalika	0.3
528	Rasuwa	Kalika Gaunpalika	0.3	565	Rukum_W	Chaurjahari Nagarpalika	0.35
529	Rasuwa	Naukunda Gaunpalika	0.3	566	Rukum_W	Musikot Nagarpalika	0.35
530	Rasuwa	Parbati Kunda Gaunpalika	0.3	567	Rukum_W	Sani Bheri Gaunpalika	0.35
531	Rasuwa	Uttargaya Gaunpalika	0.3	568	Rukum_W	Tribeni Gaunpalika	0.35
532	Rautahat	Baudhimai Nagarpalika	0.3	569	Rupandehi	Butwal Upamahanagarpalika	0.35
533	Rautahat	Brindaban Nagarpalika	0.35	570	Rupandehi	Devdaha Nagarpalika	0.35
534	Rautahat	Chandrapur Nagarpalika	0.35	571	Rupandehi	Gaidahawa Gaunpalika	0.35
535	Rautahat	Dewahhi Gonahi Nagarpalika	0.35	572	Rupandehi	Kanchan Gaunpalika	0.35
536	Rautahat	Durga Bhagwati Gaunpalika	0.3	573	Rupandehi	Kotahimai Gaunpalika	0.35
537	Rautahat	Gadhimai Nagarpalika	0.35	574	Rupandehi	Lumbini Sanskritik Nagarpalika	0.35
538	Rautahat	Garuda Nagarpalika	0.35	575	Rupandehi	Marchawari Gaunpalika	0.35
539	Rautahat	Gaur Nagarpalika	0.3	576	Rupandehi	Mayadevi Gaunpalika	0.35
540	Rautahat	Gujara Nagarpalika	0.35	577	Rupandehi	Omsatiya Gaunpalika	0.35
541	Rautahat	Ishanath Nagarpalika	0.3	578	Rupandehi	Rohini Gaunpalika	0.35
542	Rautahat	Katahariya Nagarpalika	0.35	579	Rupandehi	Sainamaina Nagarpalika	0.35
543	Rautahat	Madhav Narayan Nagarpalika	0.3	580	Rupandehi	Sammarimai Gaunpalika	0.35
544	Rautahat	Maulapur Nagarpalika	0.35	581	Rupandehi	Siddharthanagar Nagarpalika	0.35
545	Rautahat	Paroha Nagarpalika	0.3	582	Rupandehi	Siyari Gaunpalika	0.35
546	Rautahat	Phatuwa Bijayapur Nagarpalika	0.35	583	Rupandehi	Sudhdhodhan Gaunpalika	0.35
547	Rautahat	Rajdevi Nagarpalika	0.3	584	Rupandehi	Tillotama Nagarpalika	0.35
548	Rautahat	Rajpur Nagarpalika	0.3	585	Salyan	Bagchaur Nagarpalika	0.35
549	Rautahat	Yemunamai Gaunpalika	0.3	586	Salyan	Bangad Kupinde Nagarpalika	0.35
550	Rolpa	Duikholi Gaunpalika	0.35	587	Salyan	Chhatreshwori Gaunpalika	0.35
551	Rolpa	Lungri Gaunpalika	0.35	588	Salyan	Darma Gaunpalika	0.35
552	Rolpa	Madi Gaunpalika	0.35	589	Salyan	Dhorchaur Gaunpalika	0.35
553	Rolpa	Rolpa Nagarpalika	0.35	590	Salyan	Kalimati Gaunpalika	0.4
554	Rolpa	Runtigadi Gaunpalika	0.35	591	Salyan	Kapurkot Gaunpalika	0.35
555	Rolpa	Sukidaha Gaunpalika	0.35	592	Salyan	Kumakhmalika Gaunpalika	0.35

SN	District	Local Units	PGA	SN	District	Local Units	PGA
593	Salyan	Sharada Nagarpalika	0.35	630	Sarlahi	Chandranagar Gaunpalika	0.35
594	Salyan	Tribeni Gaunpalika	0.35	631	Sarlahi	Dhankaul Gaunpalika	0.35
595	Sankhuwasabha	Bhotkhola Gaunpalika	0.3	632	Sarlahi	Godaita Nagarpalika	0.3
596	Sankhuwasabha	Chainpur Nagarpalika	0.35	633	Sarlahi	Haripur Nagarpalika	0.35
597	Sankhuwasabha	Chichila Gaunpalika	0.3	634	Sarlahi	Haripurwa Nagarpalika	0.35
598	Sankhuwasabha	Dharmadevi Nagarpalika	0.35	635	Sarlahi	Hariwan Nagarpalika	0.35
599	Sankhuwasabha	Khandbari Nagarpalika	0.35	636	Sarlahi	Ishworpur Nagarpalika	0.35
600	Sankhuwasabha	Madi Nagarpalika	0.35	637	Sarlahi	Kabilasi Nagarpalika	0.35
601	Sankhuwasabha	Makalu Gaunpalika	0.3	638	Sarlahi	Kaudena Gaunpalika	0.35
602	Sankhuwasabha	Panchakhapan Nagarpalika	0.35	639	Sarlahi	Lalbandi Nagarpalika	0.35
603	Sankhuwasabha	Sabhapokhari Gaunpalika	0.3	640	Sarlahi	Malangawa Nagarpalika	0.35
604	Sankhuwasabha	Silichong Gaunpalika	0.3	641	Sarlahi	Parsa Gaunpalika	0.35
605	Saptari	Agnisair Krishna Savaran Gaunpalika	0.35	642	Sarlahi	Ramnagar Gaunpalika	0.3
606	Saptari	Balan Bihul Gaunpalika	0.35	643	Sindhuli	Dudhouli Nagarpalika	0.35
607	Saptari	Belhi Chapena Gaunpalika	0.35	644	Sindhuli	Ghanglekh Gaunpalika	0.35
608	Saptari	Bishnupur Gaunpalika	0.35	645	Sindhuli	Golanjor Gaunpalika	0.35
609	Saptari	Bode Barsain Nagarpalika	0.35	646	Sindhuli	Hariharpurgadhi Gaunpalika	0.35
610	Saptari	Chhinmasta Gaunpalika	0.35	647	Sindhuli	Kamalamai Nagarpalika	0.4
611	Saptari	Dakneshwori Nagarpalika	0.35	648	Sindhuli	Marin Gaunpalika	0.35
612	Saptari	Hanumannagar Kankalini Nagarpalika	0.35	649	Sindhuli	Phikkal Gaunpalika	0.35
613	Saptari	Kanchanrup Nagarpalika	0.35	650	Sindhuli	Sunkoshi Gaunpalika	0.35
614	Saptari	Khadak Nagarpalika	0.4	651	Sindhuli	Tinpatan Gaunpalika	0.35
615	Saptari	Mahadeva Gaunpalika	0.35	652	Sindhupalchowk	Balefi Gaunpalika	0.35
616	Saptari	Rajbiraj Nagarpalika	0.35	653	Sindhupalchowk	Barhabise Nagarpalika	0.3
617	Saptari	Rupani Gaunpalika	0.35	654	Sindhupalchowk	Bhotekoshi Gaunpalika	0.3
618	Saptari	Saptakoshi Nagarpalika	0.4	655	Sindhupalchowk	Chautara SangachokGadhi Nagarpalika	0.35
619	Saptari	Shambhunath Nagarpalika	0.35	656	Sindhupalchowk	Helambu Gaunpalika	0.3
620	Saptari	Surunga Nagarpalika	0.4	657	Sindhupalchowk	Indrawati Gaunpalika	0.35
621	Saptari	Tilathi Koiladi Gaunpalika	0.35	658	Sindhupalchowk	Jugal Gaunpalika	0.3
622	Saptari	Tirahut Gaunpalika	0.35	659	Sindhupalchowk	Lisangkhu Pakhar Gaunpalika	0.35
623	Sarlahi	Bagmati Nagarpalika	0.35	660	Sindhupalchowk	Melamchi Nagarpalika	0.35
624	Sarlahi	Balara Nagarpalika	0.3	661	Sindhupalchowk	Panchpokhari Thangpal Gaunpalika	0.3
625	Sarlahi	Barahathawa Nagarpalika	0.35	662	Sindhupalchowk	Sunkoshi Gaunpalika	0.35
626	Sarlahi	Basbariya Gaunpalika	0.35	663	Sindhupalchowk	Tripurasundari Gaunpalika	0.3
627	Sarlahi	Bishnu Gaunpalika	0.3	664	Siraha	Arnama Gaunpalika	0.35
628	Sarlahi	Bramhapuri Gaunpalika	0.35	665	Siraha	Aurahi Gaunpalika	0.35
629	Sarlahi	Chakraghatta Gaunpalika	0.35	666	Siraha	Bariyarpatti Gaunpalika	0.35

SN	District	Local Units	PGA	SN	District	Local Units	PGA
667	Siraha	Bhagawanpur Gaunpalika	0.35	704	Surkhet	Chaukune Gaunpalika	0.35
668	Siraha	Bishnupur Gaunpalika	0.35	705	Surkhet	Chingad Gaunpalika	0.35
669	Siraha	Dhangadhimai Nagarpalika	0.4	706	Surkhet	Gurbhakot Nagarpalika	0.4
670	Siraha	Golbazar Nagarpalika	0.4	707	Surkhet	Lekbeshi Nagarpalika	0.4
671	Siraha	Kalyanpur Nagarpalika	0.35	708	Surkhet	Panchpuri Nagarpalika	0.35
672	Siraha	Karjanha Nagarpalika	0.35	709	Surkhet	Simta Gaunpalika	0.35
673	Siraha	Lahan Nagarpalika	0.4	710	Syangja	Aandhikhola Gaunpalika	0.35
674	Siraha	Laxmipur Patari Gaunpalika	0.35	711	Syangja	Arjunchaupari Gaunpalika	0.35
675	Siraha	Mirchaiya Nagarpalika	0.35	712	Syangja	Bhirkot Nagarpalika	0.35
676	Siraha	Naraha Gaunpalika	0.35	713	Syangja	Biruwa Gaunpalika	0.35
677	Siraha	Nawarajpur Gaunpalika	0.35	714	Syangja	Chapakot Nagarpalika	0.35
678	Siraha	Sakhuwanankarkatti Gaunpalika	0.35	715	Syangja	Galyang Nagarpalika	0.35
679	Siraha	Siraha Nagarpalika	0.35	716	Syangja	Harinas Gaunpalika	0.35
680	Siraha	Sukhipur Nagarpalika	0.35	717	Syangja	Kaligandagi Gaunpalika	0.35
681	Solukhumbu	Dudhkoshi Gaunpalika	0.3	718	Syangja	Phedikhola Gaunpalika	0.35
682	Solukhumbu	Khumbupasanglahmu Gaunpalika	0.3	719	Syangja	Putalibazar Nagarpalika	0.35
683	Solukhumbu	Likhupike Gaunpalika	0.3	720	Syangja	Waling Nagarpalika	0.35
684	Solukhumbu	Mahakulung Gaunpalika	0.3	721	Tanahu	Anbukhaireni Gaunpalika	0.35
685	Solukhumbu	Nechasalyan Gaunpalika	0.35	722	Tanahu	Bandipur Gaunpalika	0.35
686	Solukhumbu	Solududhakunda Nagarpalika	0.3	723	Tanahu	Bhanu Nagarpalika	0.35
687	Solukhumbu	Sotang Gaunpalika	0.3	724	Tanahu	Bhimad Nagarpalika	0.35
688	Solukhumbu	Thulung Dudhkoshi Gaunpalika	0.35	725	Tanahu	Byas Nagarpalika	0.35
689	Sunsari	Barah Nagarpalika	0.4	726	Tanahu	Devghat Gaunpalika	0.35
690	Sunsari	Barju Gaunpalika	0.35	727	Tanahu	Ghiring Gaunpalika	0.35
691	Sunsari	Bhokraha Narsingh Gaunpalika	0.35	728	Tanahu	Myagde Gaunpalika	0.35
692	Sunsari	Dewanganj Gaunpalika	0.35	729	Tanahu	Rhishing Gaunpalika	0.35
693	Sunsari	Dharan Upamahanagarpalika	0.4	730	Tanahu	Shuklagandaki Nagarpalika	0.35
694	Sunsari	Duhabi Nagarpalika	0.35	731	Taplejung	Aathrai Tribeni Gaunpalika	0.35
695	Sunsari	Gadhi Gaunpalika	0.35	732	Taplejung	Maiwakhola Gaunpalika	0.35
696	Sunsari	Harinagar Gaunpalika	0.35	733	Taplejung	Meringden Gaunpalika	0.3
697	Sunsari	Inaruwa Nagarpalika	0.35	734	Taplejung	Mikwakhola Gaunpalika	0.3
698	Sunsari	Itahari Upamahanagarpalika	0.35	735	Taplejung	Pathibhara Yangwarak Gaunpalika	0.35
699	Sunsari	Koshi Gaunpalika	0.35	736	Taplejung	Phaktanglung Gaunpalika	0.25
700	Sunsari	Ramdhuni Nagarpalika	0.35	737	Taplejung	Phungling Nagarpalika	0.3
701	Surkhet	Barahtal Gaunpalika	0.35	738	Taplejung	Sidingba Gaunpalika	0.3
702	Surkhet	Bheriganga Nagarpalika	0.4	739	Taplejung	Sirijangha Gaunpalika	0.3
703	Surkhet	Birendranagar Nagarpalika	0.4	740	Tehrathum	Aathrai Gaunpalika	0.35

SN	District	Local Units	PGA
741	Tehrathum	Chhathar Gaunpalika	0.35
742	Tehrathum	Laligurans Nagarpalika	0.35
743	Tehrathum	Menchayam Gaunpalika	0.35
744	Tehrathum	Myanglung Nagarpalika	0.35
745	Tehrathum	Phedap Gaunpalika	0.35
746	Udayapur	Belaka Nagarpalika	0.4
747	Udayapur	Chaudandigadhi Nagarpalika	0.4
748	Udayapur	Katari Nagarpalika	0.4
749	Udayapur	Rautamai Gaunpalika	0.4
750	Udayapur	Sunkoshi Gaunpalika	0.35
751	Udayapur	Tapli Gaunpalika	0.35
752	Udayapur	Triyuga Nagarpalika	0.4
753	Udayapur	Udayapurgadhi Gaunpalika	0.4